

SYNERGEE®

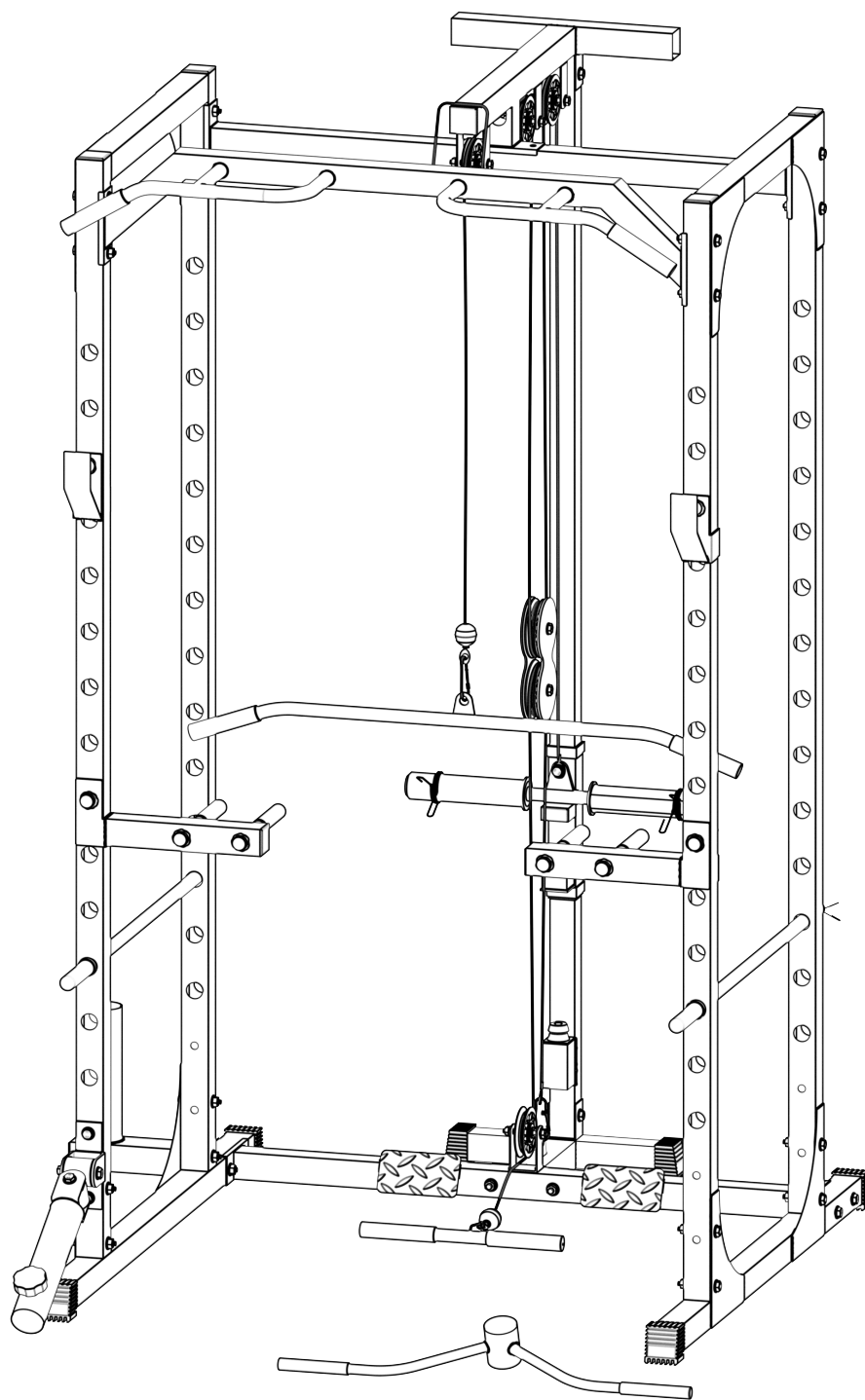







POWER RACK WITH PULLEY

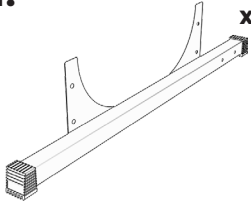
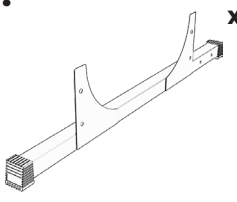
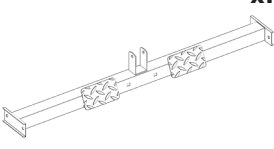
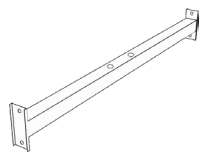
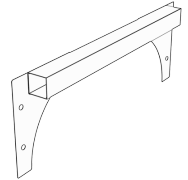
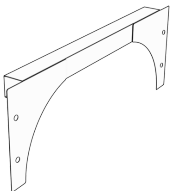
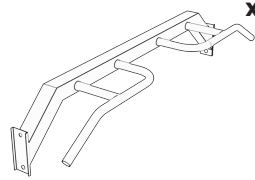
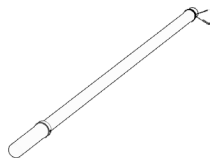
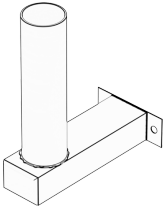
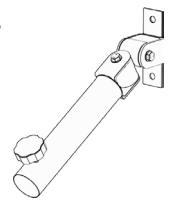

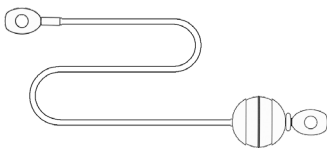
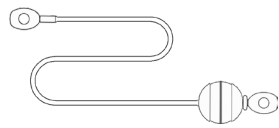
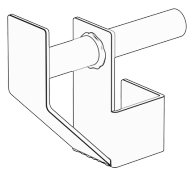
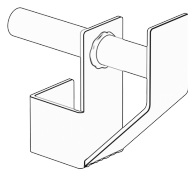
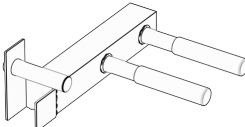
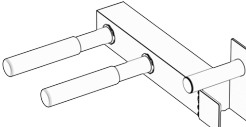
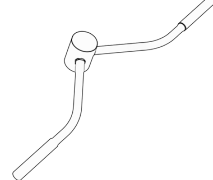
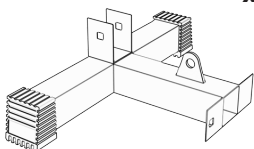
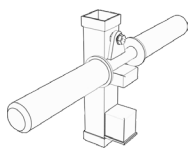
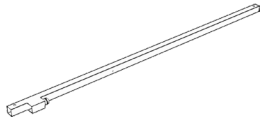
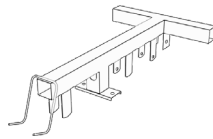
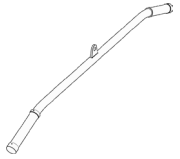
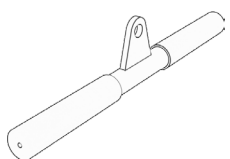

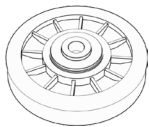
PARTS LIST

IF ANY PIECES ARE MISSING, PLEASE CONTACT US IMMEDIATELY:
HELLO@SYNERGEEFITNESS.COM OR 1.855.217.7136

<p>1. QTY x1</p>  <p>LEFT BASE</p>	<p>2. QTY x1</p>  <p>RIGHT BASE</p>	<p>3. QTY x1</p>  <p>LOWER STABILIZER</p>	<p>4. QTY x1</p>  <p>UPPER STABILIZER</p>	<p>5. QTY x1</p>  <p>UPPER FRAME LEFT</p>
<p>6. QTY x1</p>  <p>UPPER FRAME RIGHT</p>	<p>7. QTY x1</p>  <p>PULL-UP BAR</p>	<p>8. QTY x2</p>  <p>SAFETY BAR</p>	<p>9. QTY x1</p>  <p>BARBELL STORAGE</p>	<p>10. QTY x1</p>  <p>LANDMINE ATTACHMENT</p>
<p>11. QTY x4</p>  <p>UPRIGHT</p>		<p>12. QTY x1</p>  <p>Long Cable (120")</p>	<p>13. QTY x1</p>  <p>Short Cable (107")</p>	
<p>14. QTY x1</p>  <p>RIGHT J-CUP</p>	<p>15. QTY x1</p>  <p>LEFT J-CUP</p>	<p>16. QTY x1</p>  <p>LEFT DIP HANDLE</p>	<p>17. QTY x1</p>  <p>RIGHT DIP HANDLE</p>	<p>18. QTY x1</p>  <p>V-BAR</p>
<p>19. QTY x1</p>  <p>Lower Cable Frame</p>	<p>20. QTY x1</p>  <p>LOADABLE SLEEVES</p>	<p>21. QTY x1</p>  <p>PULLEY SYSTEM UPRIGHT</p>	<p>22. QTY x1</p>  <p>UPPER PULLEY SYSTEM</p>	<p>23. QTY x1</p>  <p>LAT PULL DOWN BAR</p>
<p>24. QTY x1</p>  <p>STRAIGHT BAR</p>	<p>25. QTY x3</p>  <p>CARABINER</p>	<p>26. QTY x6</p>  <p>PULLEY WHEEL</p>	<p>27. QTY x2</p>  <p>PULLEY PLATE</p>	

PARTS LIST

IF ANY PIECES ARE MISSING, PLEASE CONTACT US IMMEDIATELY:
HELLO@SYNERGEEFITNESS.COM OR 1.855.217.7136

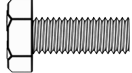
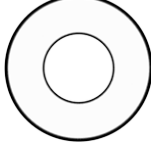
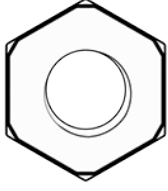
<p>A. QTY x28</p>  <p>M10x70 FULLY THREADED BOLT</p>	<p>B. QTY x6</p>  <p>M10x45 FULLY THREADED BOLT</p>	<p>C. QTY x1</p>  <p>M10x20 FULLY THREADED BOLT</p>	<p>D. QTY x35</p>  <p>M10 WASHER</p>	<p>E. QTY x35</p>  <p>M10 NUT</p>
---	--	--	---	--

HARDWARE SIZING CHART

**M10x20
BOLT**

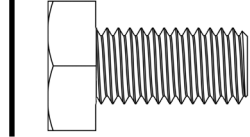

**M10x45
BOLT**

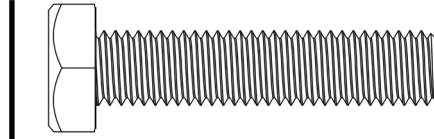

**M10x70
BOLT**

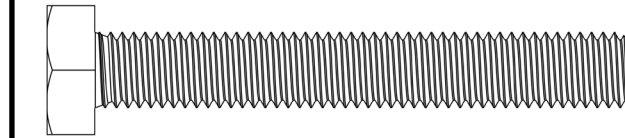

ASSEMBLY

STEP: 1

STEP PART GUIDE

#	PART NAME	QTY
1.	LEFT BASE	1
2.	RIGHT BASE	1
3.	LOWER STABILIZER	1
9.	BARBELL STORAGE	1
A.	M10x70 BOLT	4
D.	M10 WASHER	4
E.	M10 NUT	4

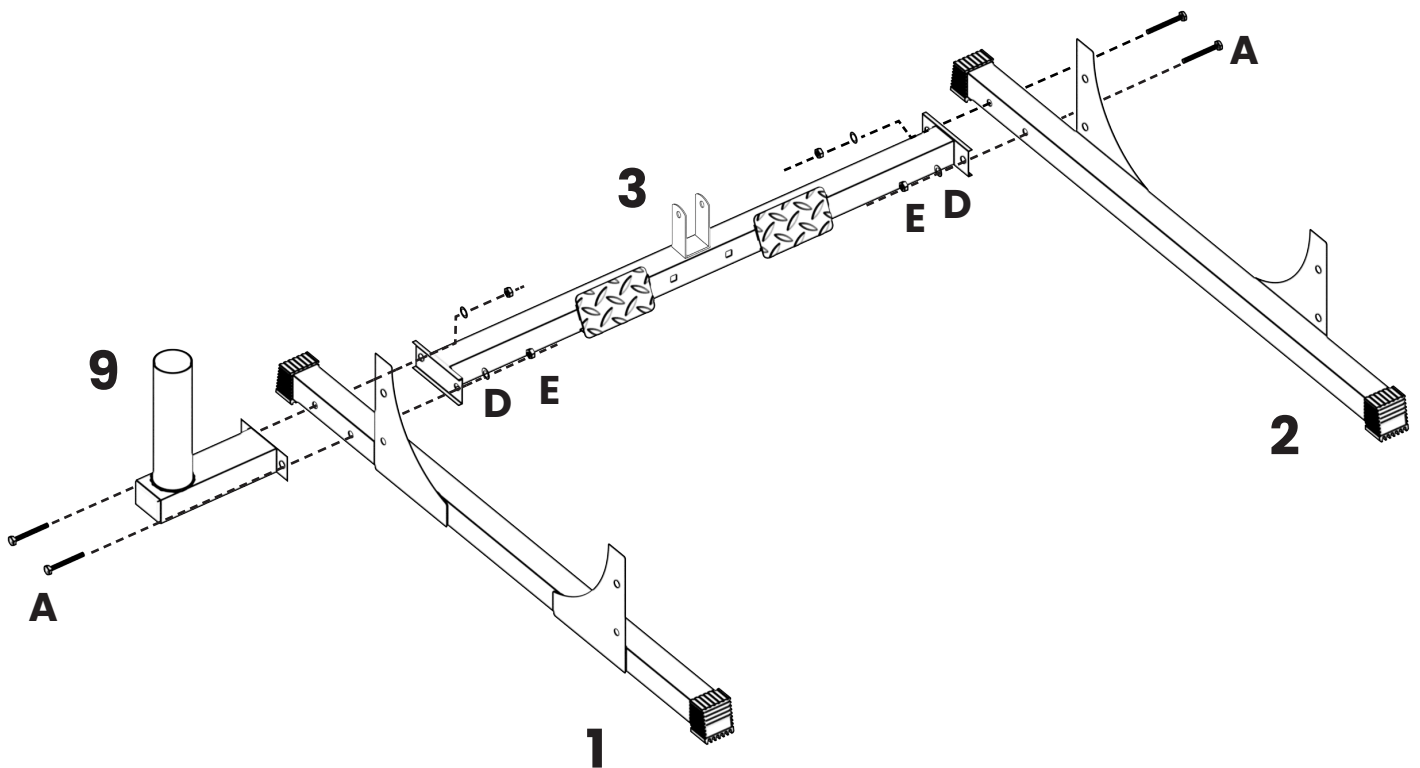

ASSEMBLY

STEP: 2

STEP PART GUIDE

#	PART NAME	QTY
11.	UPRIGHT	4
A.	M10X70 BOLT	8
D.	M10 WASHER	8
E.	M10 NUT	8

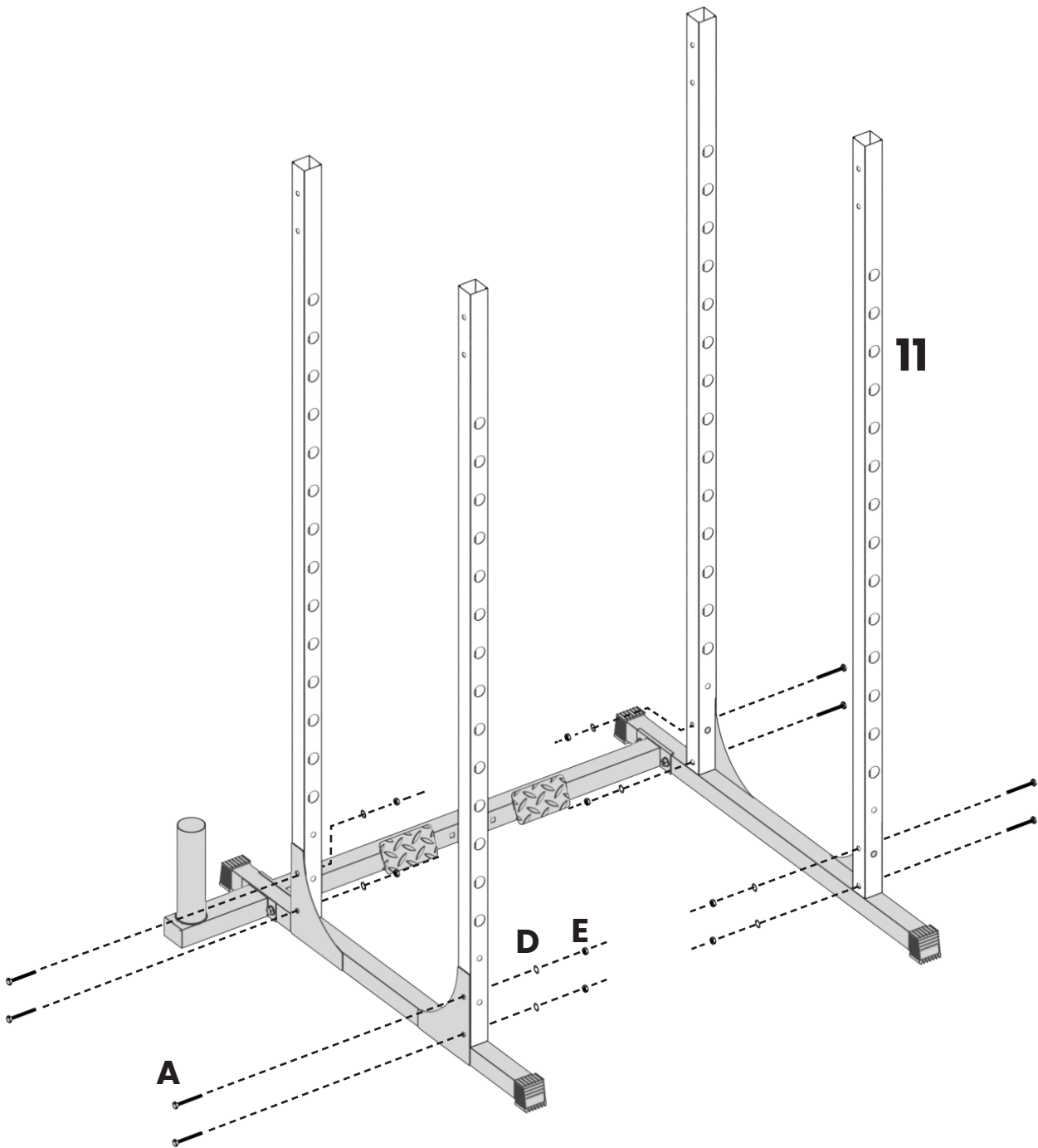

ASSEMBLY

STEP: 3

STEP PART GUIDE

#	PART NAME	QTY
4.	UPPER STABALZIER	1
5.	LEFT UPPER FRAME	1
6.	RIGHT UPPER FRAME	1
7.	PULL-UP BAR	1
A.	M10X70 BOLT	8
D.	M10 WASHER	8
E.	M10 NUT	8

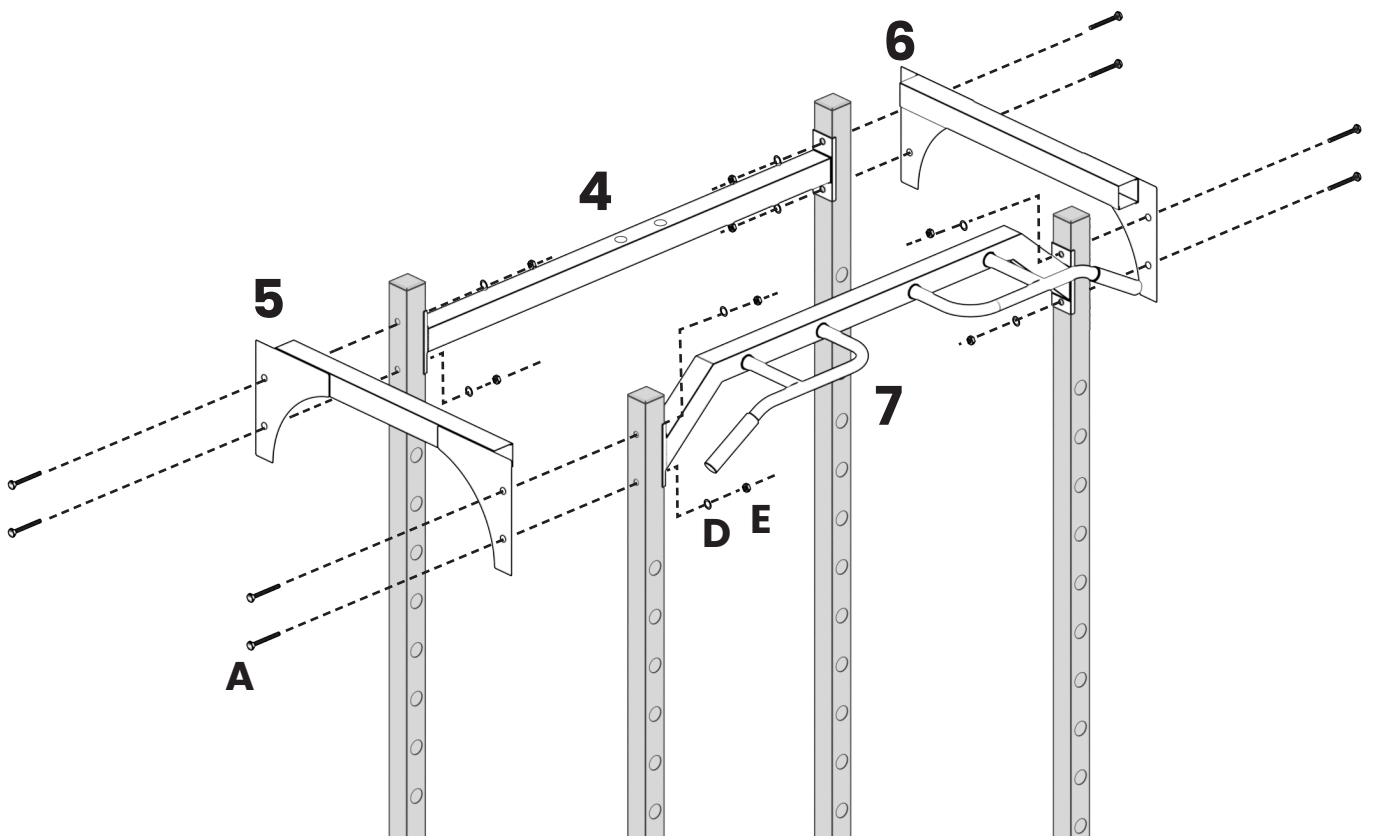

ASSEMBLY

STEP: 4

STEP PART GUIDE

#	PART NAME	QTY
19.	LOWER CABLE FRAME	1
A.	M10X70 BOLT	2
D.	M10 WASHER	2
E.	M10 NUT	2

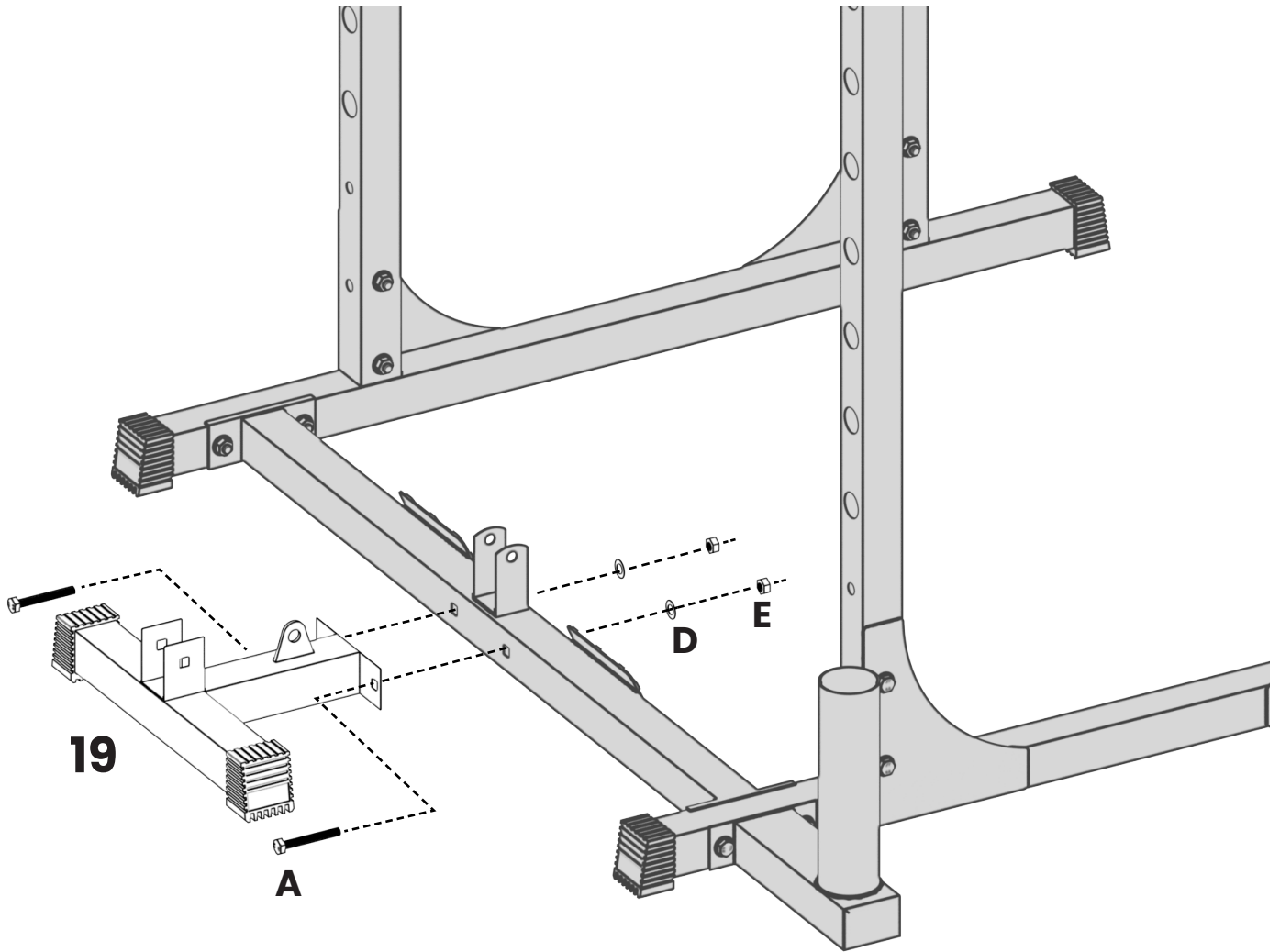

ASSEMBLY

STEP: 5

STEP PART GUIDE

#	PART NAME	QTY
20.	LOADABLE SLEEVES	1
21.	PULLEY SYSTEM UPRIGHT	1
A.	M10X70 BOLT	1
D.	M10 WASHER	1
E.	M10 NUT	1

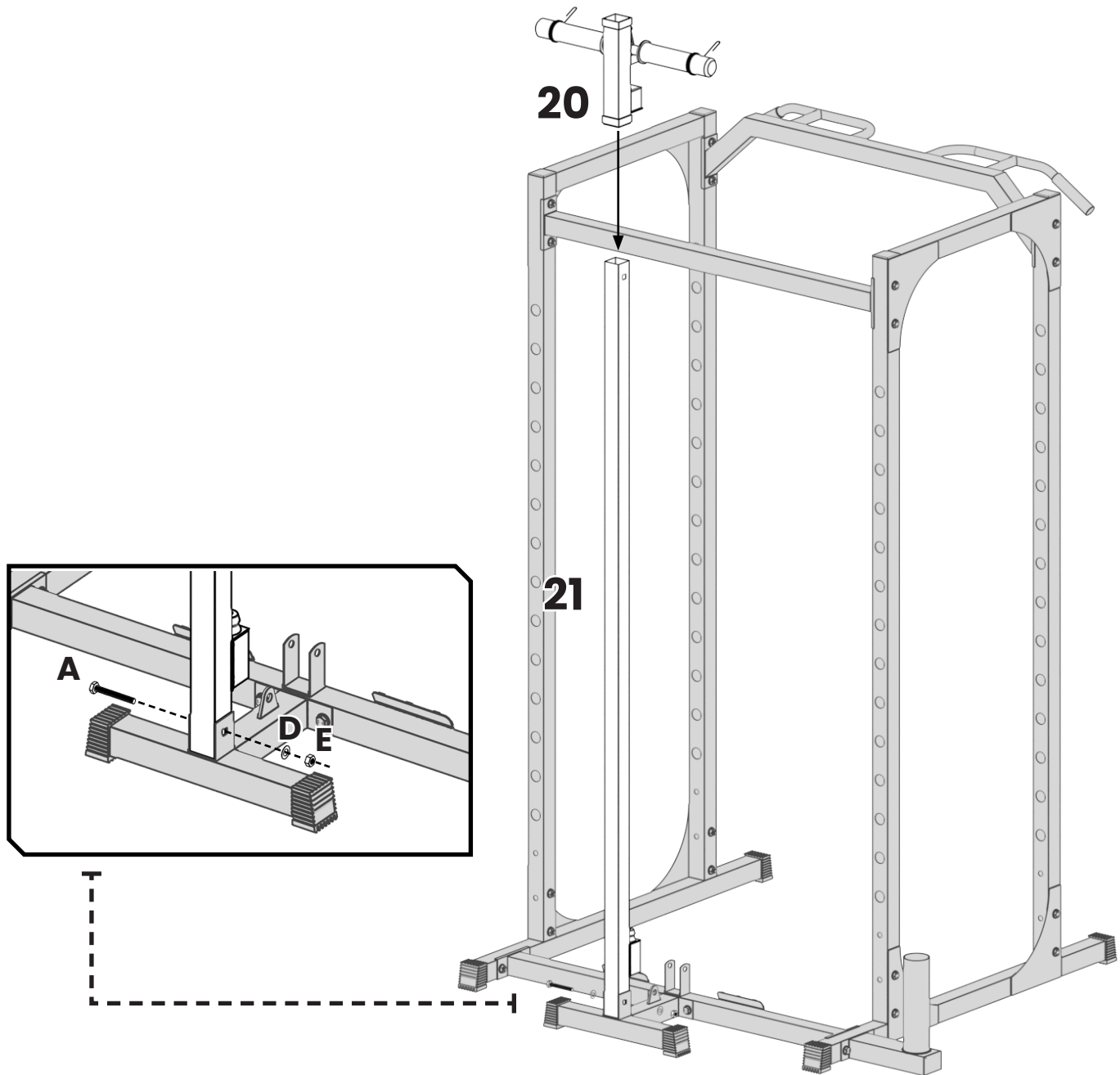

ASSEMBLY

STEP: 6

STEP PART GUIDE

#	PART NAME	QTY
22.	UPPER PULLEY SYSTEM	1
A.	M10X70 BOLT	3
D.	M10 WASHER	3
E.	M10 NUT	3

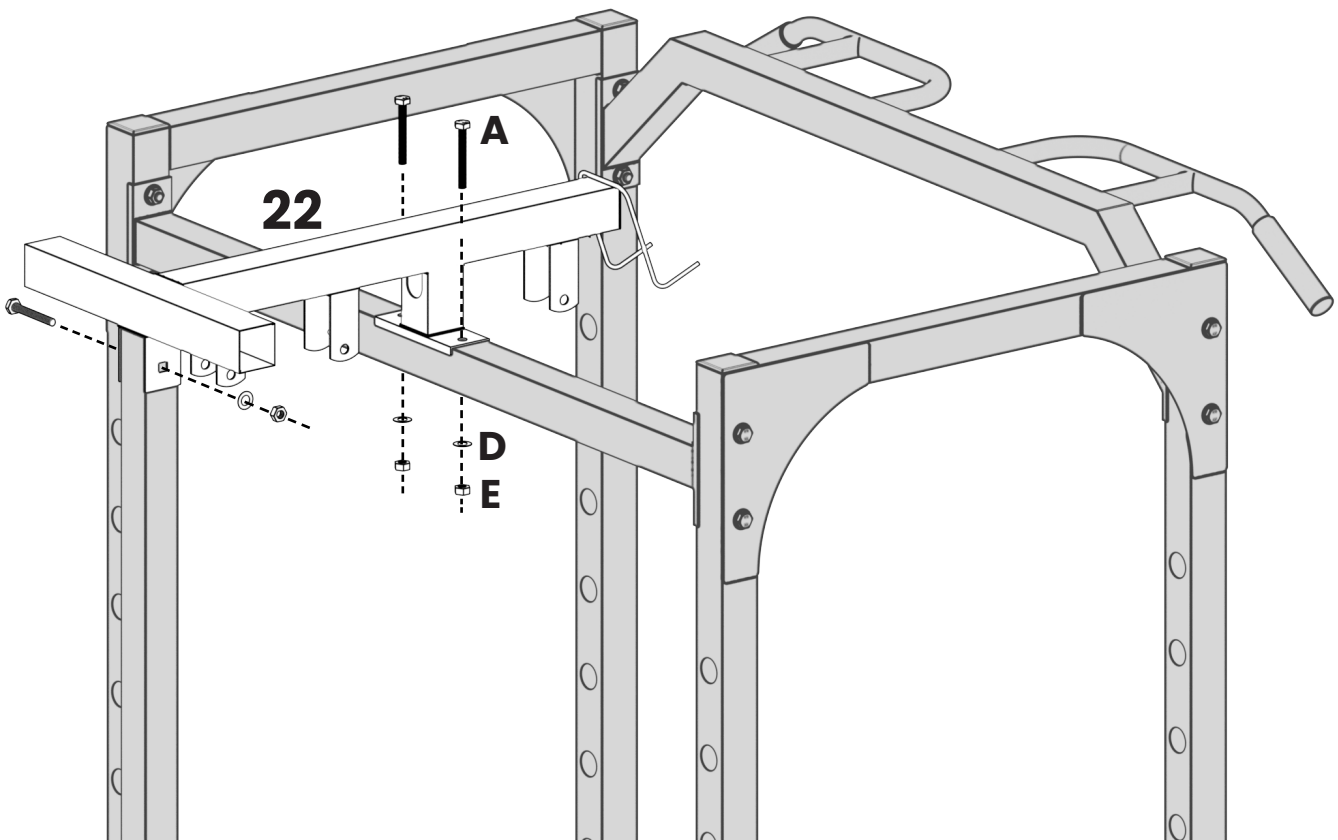

ASSEMBLY

STEP: 7

STEP PART GUIDE

#	PART NAME	QTY
26.	PULLEY WHEEL	4
B.	M10x45 BOLT	4
D.	M10 WASHER	4
E.	M10 NUT	4

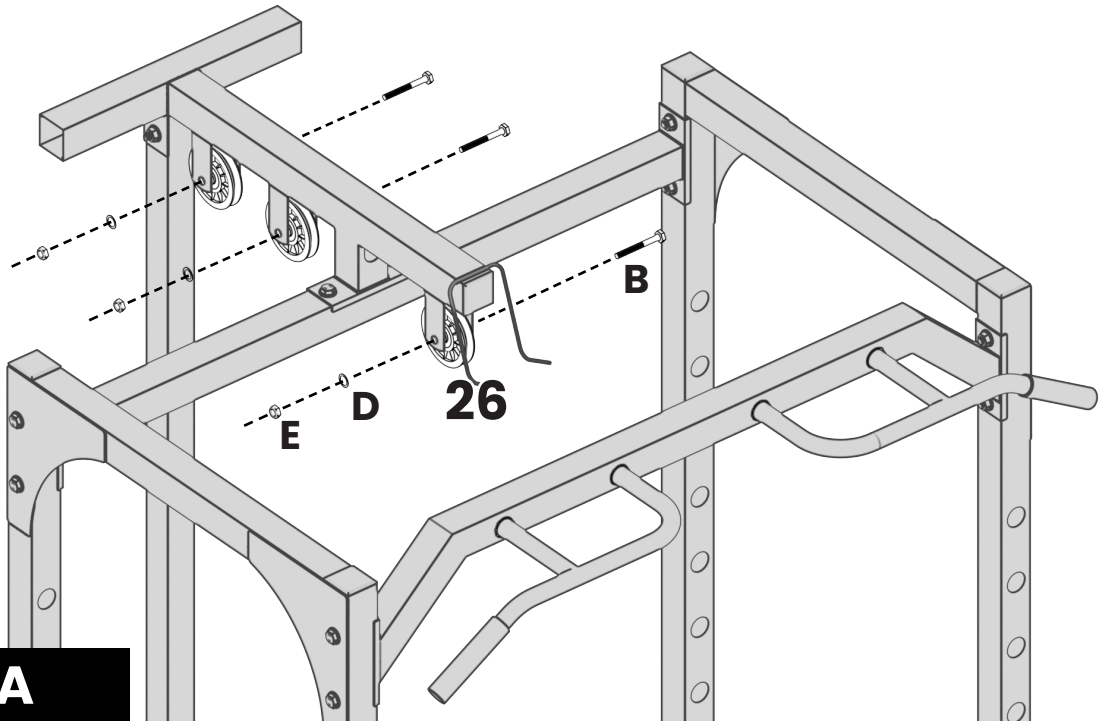

PART A

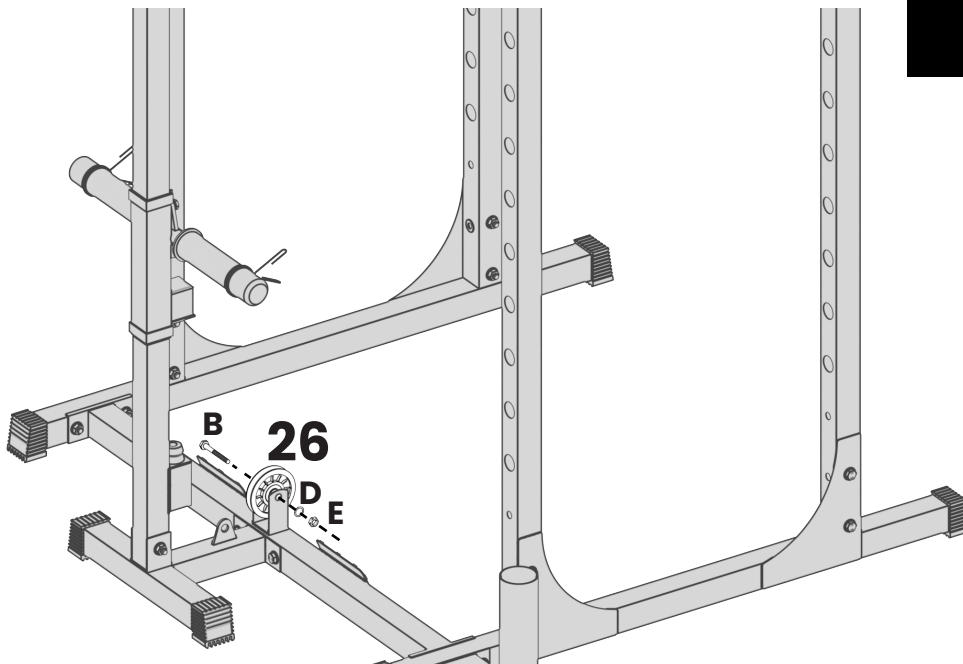

PART B

ASSEMBLY

STEP: 8

STEP PART GUIDE

#	PART NAME	QTY
26.	PULLEY WHEEL	2
27.	PULLEY PLATE	2
B.	M10X45 BOLT	2
D.	M10 WASHER	2
E.	M10 NUT	2

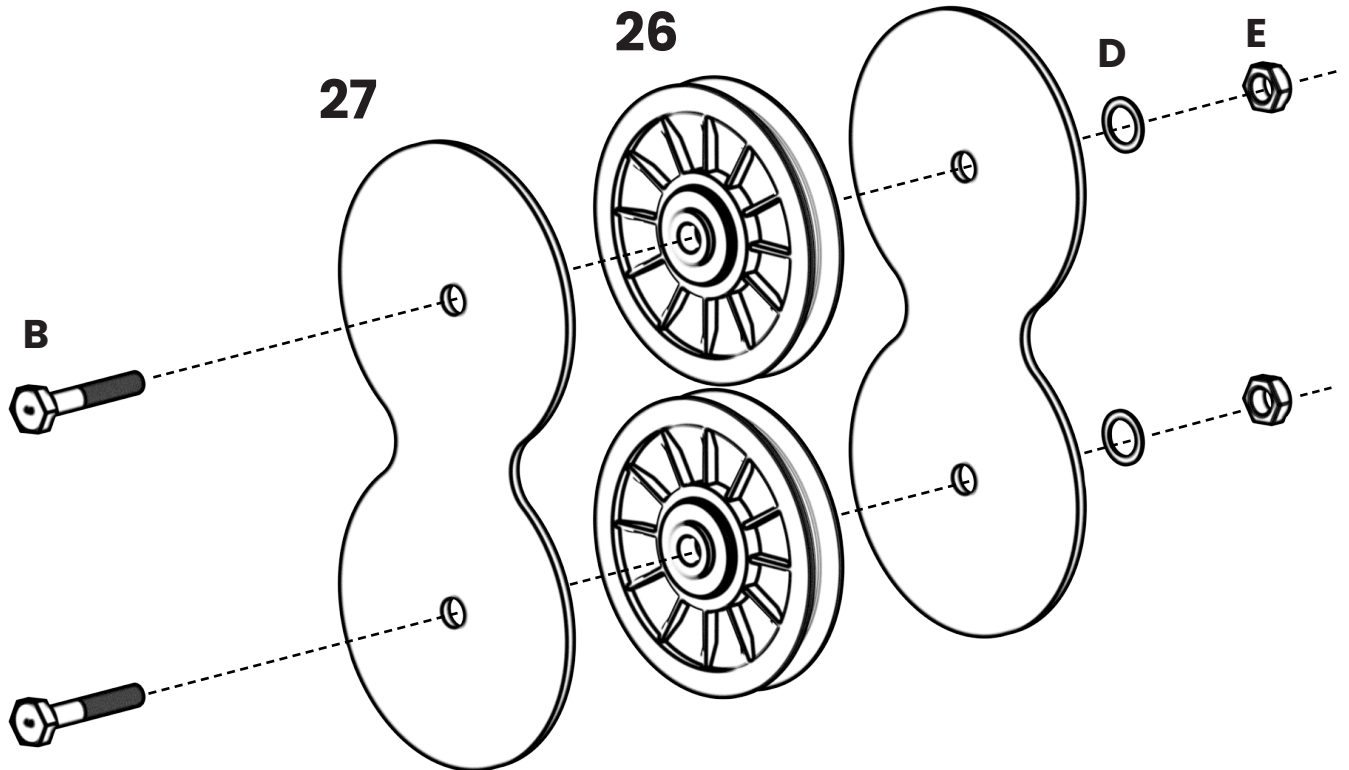

ASSEMBLY

STEP: 9

STEP PART GUIDE

#	PART NAME	QTY
12.	LONG CABLE	1
13.	SHORT CABLE	1
23.	LAT PULLDOWN BAR	1
24.	STRAIGHT BAR	1
25.	CARABINER	3
A-1.	ASSEMBLY FROM STEP 8	1
C.	M10x20 BOLT	1
D.	M10 WASHER	1
E.	M10 NUT	1

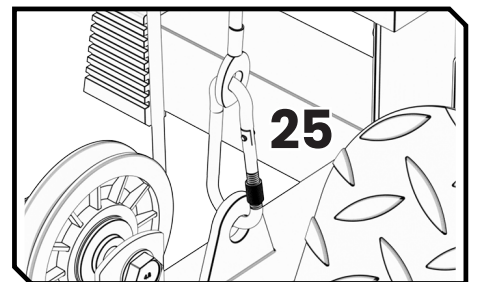
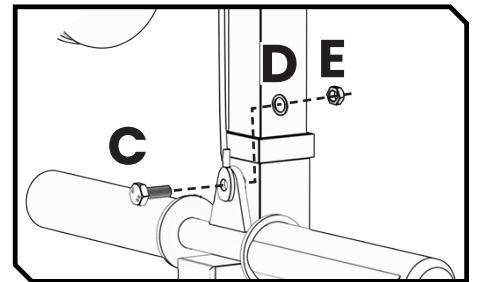
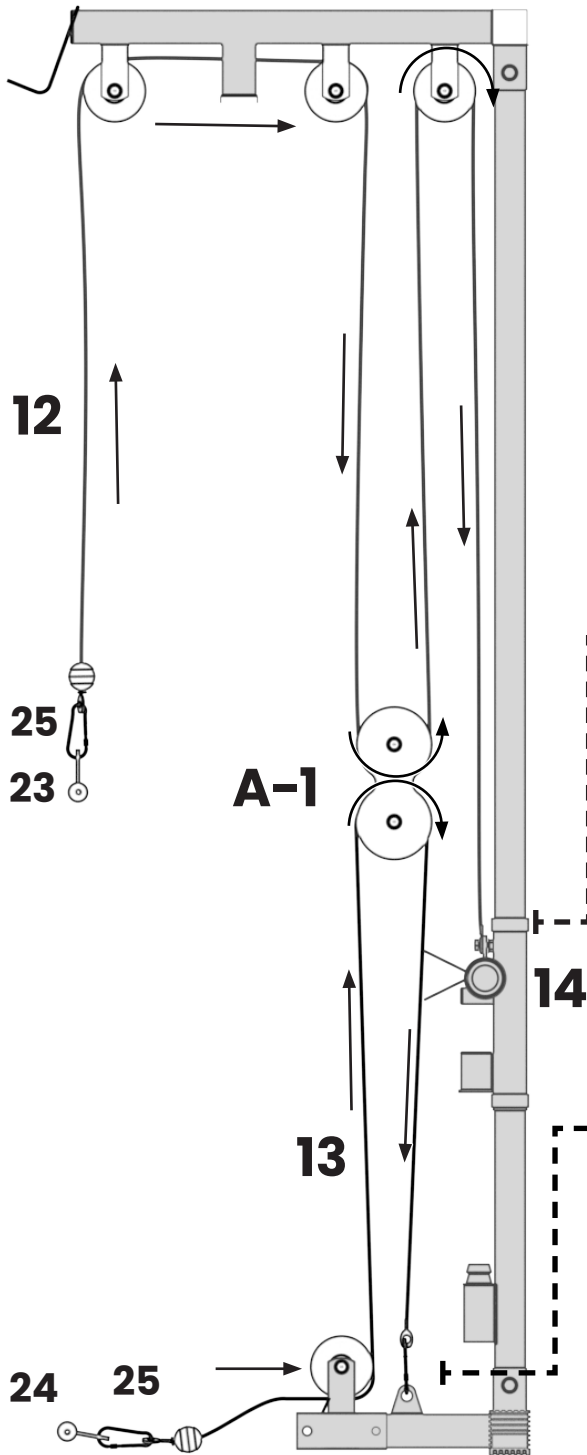

ASSEMBLY

STEP: 10

STEP PART GUIDE

#	PART NAME	QTY
8.	SAFETY BARS	2
10.	LANDMINE	1
14.	RIGHT J-CUP	1
15.	LEFT J-CUP	1
16.	LEFT DIP BAR	1
17.	RIGHT DIP BAR	1
18.	V-BAR	1
A.	M10X70 BOLT	2
D.	M10 WASHER	2
E.	M10 NUT	2

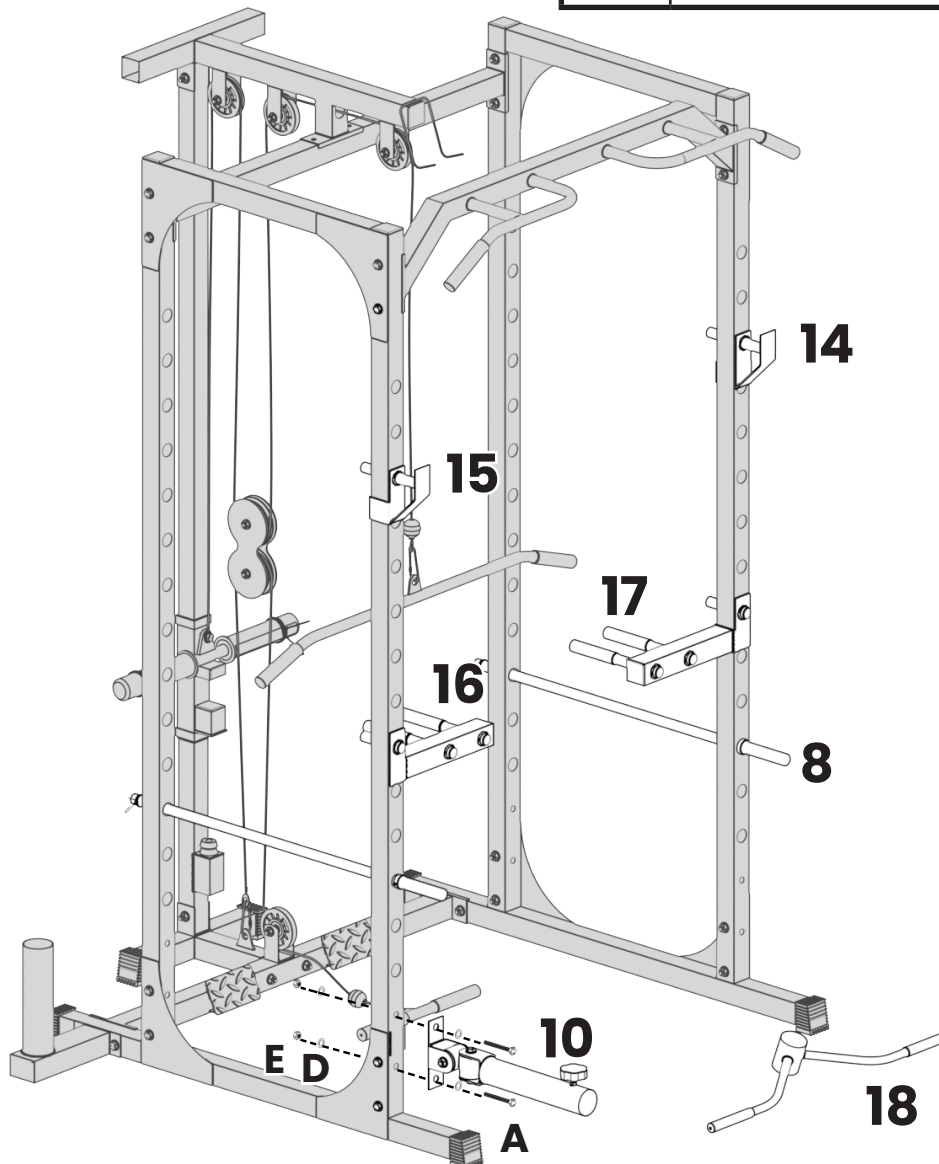

WARNING

Follow these precautions to ensure you use your Synergee Power Rack safely:

As with any workout equipment that involves heavy weights, there is a risk of injury when using the Synergee Power rack. The best way to reduce the risk of serious injury is to exercise caution. Follow the instructions in this manual and familiarize yourself with all warnings on your product before using it.

Before beginning any exercise program, consult your physician. This is especially important for persons over age 35 or persons with pre-existing health issues.

THE MAXIMUM WEIGHT CAPACITY FOR THIS SQUAT RACK IS 750 LBS.

Do not load 750lbs or more onto this squat rack. If you consistently lift 700 lbs or more on a regular basis, consider working with our racks that can accommodate a higher weight capacity. Furthermore, this max weight capacity is calculated with the condition that the rack is bolted to the floor.

Follow these precautions to ensure you use your Synergee Power Rack safely:

1. Read all instructions in this manual and all warnings on the product before using it. It is the responsibility of the owner to ensure that all users of this product are adequately informed of all the safety precautions.
2. Use this product only as described in this manual and keep this manual handy for future reference.
3. Use this product only as described in this manual and keep this manual handy for future reference.
4. Always keep children and pets away from this product. Keep hands and feet away from moving parts.
5. This product is intended for consumer use only in an indoor environment. Do not use it in a commercial, rental, or institutional setting. Keep this product indoors, away from moisture and dust.
6. Place the product on a level surface, with at least 3 feet of clearance around it. To protect the floor or carpet from damage, place a mat under it.
7. Install the rack properly and according to instructions. Properly tighten all parts and check their tightness regularly. If any worn or damaged parts are found, stop usage immediately. Refrain from use until the machine has been repaired.
8. Make sure all locking mechanisms are properly secured before using the unit. Ensure adjustment pins function properly and they are fully engaged before placing any weight on the rack. Wear appropriate clothes while exercising. Do not wear loose clothes that can get caught and always wear athletic shoes while exercising.
9. Do not install any fitness product near a pool, hot tub or other damp locations. Corrosion caused by installation in these locations can lead to premature failure of components, which is not covered under any warranty.