

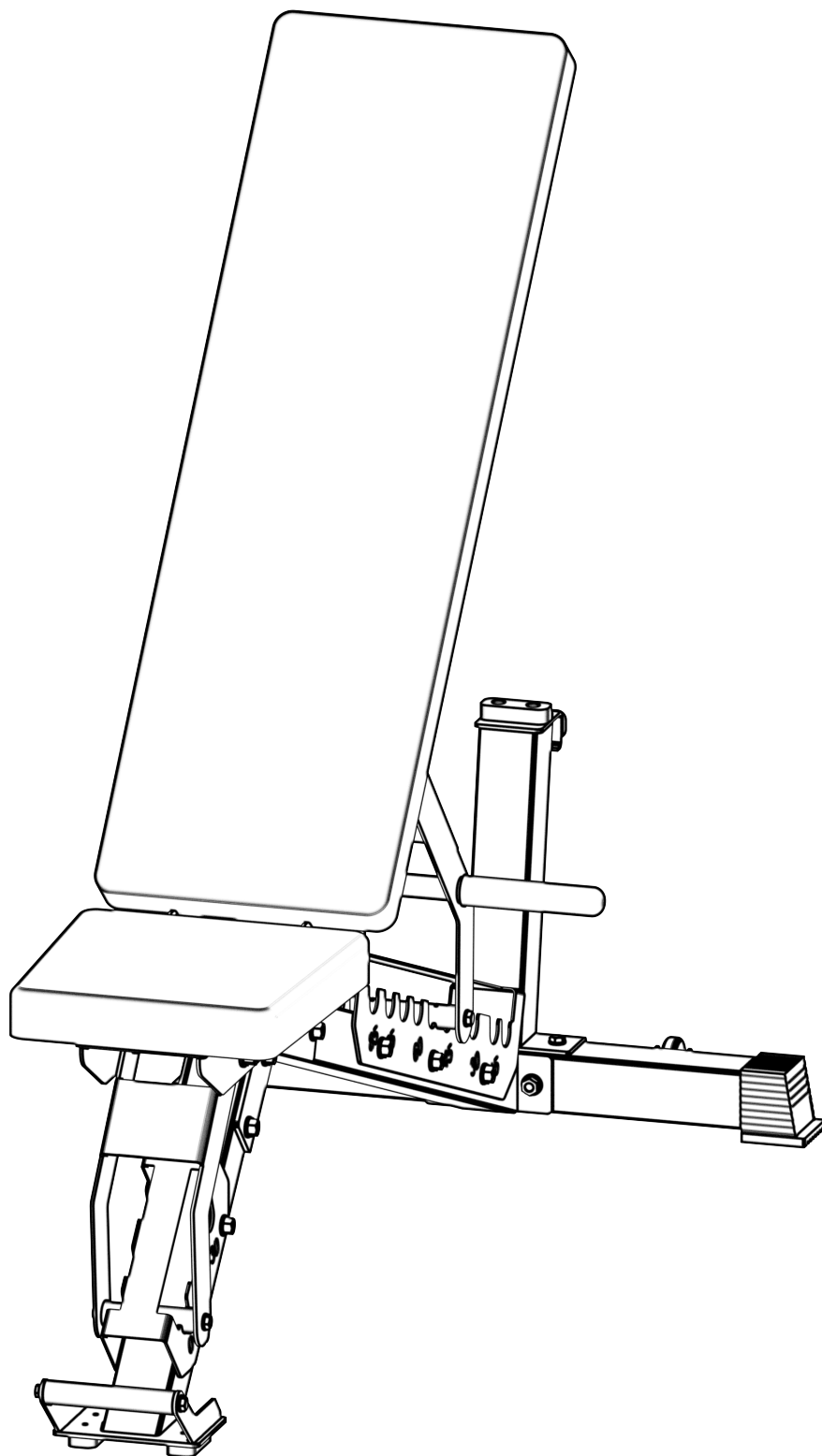

SYNERGEE[®]

AWB ADJUSTABLE BENCH





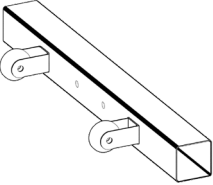
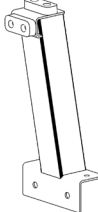
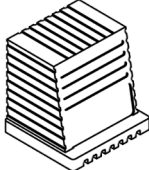
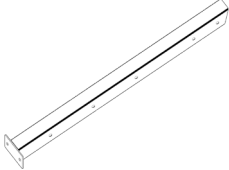
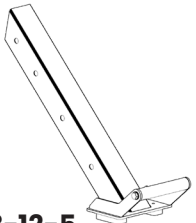
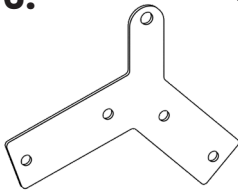
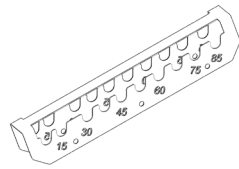
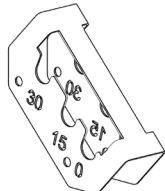
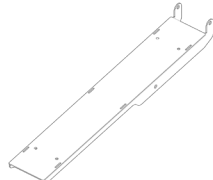
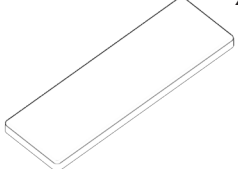
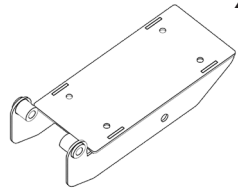
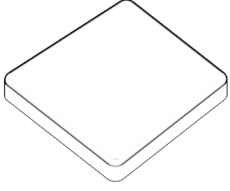
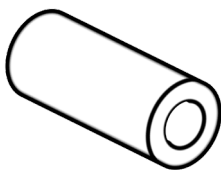
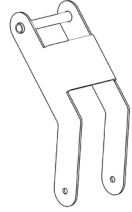
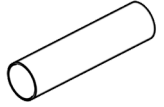
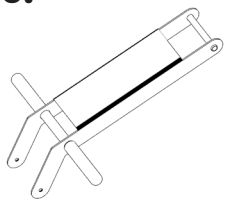
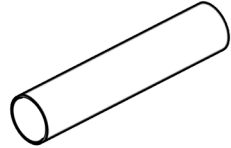



PARTS LIST

IF ANY PIECES ARE MISSING, PLEASE CONTACT US IMMEDIATELY:
HELLO@SYNERGEEFITNESS.COM OR 1.855.217.7136

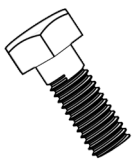
<p>1. QTY x1</p>  <p>123-12-1</p>	<p>2. QTY x1</p>  <p>123-12-2</p>	<p>3. QTY x2</p>  <p>123-12-3</p>	<p>4. QTY x1</p>  <p>123-12-4</p>	<p>5. QTY x1</p>  <p>123-12-5</p>
<p>6. QTY x2</p>  <p>123-12-6</p>	<p>7. QTY x1</p>  <p>123-12-7</p>	<p>8. QTY x1</p>  <p>123-12-8</p>	<p>9. QTY x1</p>  <p>123-12-9</p>	<p>10. QTY x1</p>  <p>123-12-10</p>
<p>11. QTY x1</p>  <p>123-12-11</p>	<p>12. QTY x1</p>  <p>123-12-12</p>	<p>13. QTY x1</p>  <p>123-12-13</p>	<p>14. QTY x1</p>  <p>142-12-14</p>	<p>15. QTY x1</p>  <p>123-12-15</p>
<p>16. QTY x1</p>  <p>123-12-16</p>	<p>17. QTY x1</p>  <p>123-12-17</p>			

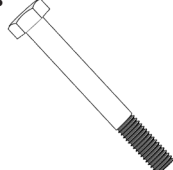
PARTS LIST

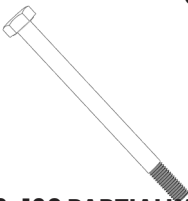
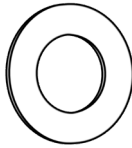
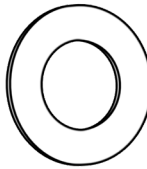
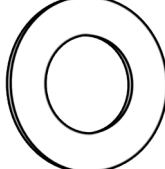
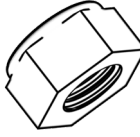
IF ANY PIECES ARE MISSING, PLEASE CONTACT US IMMEDIATELY:
HELLO@SYNERGEEFITNESS.COM OR 1.855.217.7136

A.  M8x20 FULLY THREADED BOLT	QTY x8	B.  M8x30 FULLY THREADED BOLT	QTY x6	C.  M10x80 PARTIALLY THREADED BOLT	QTY x11	D.  M12x140 PARTIALLY THREADED BOLT	QTY x1	E.  M12x160 PARTIALLY THREADED BOLT	QTY x2
F.  M8 WASHER	QTY x14	G.  M10 WASHER	QTY x22	H.  M12 WASHER	QTY x6	I.  M10 NUT	QTY x11	J.  M12 NUT	QTY x3

HARDWARE SIZING CHART

**M8x20
BOLT**

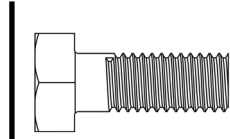

**M8x30
BOLT**

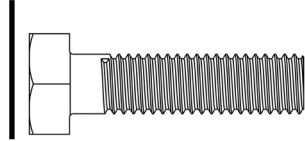

**M10x80
BOLT**

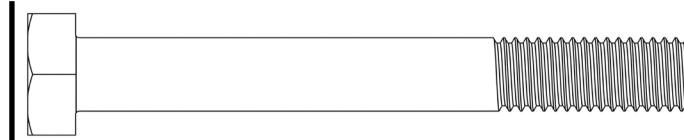

**M12x140
BOLT**

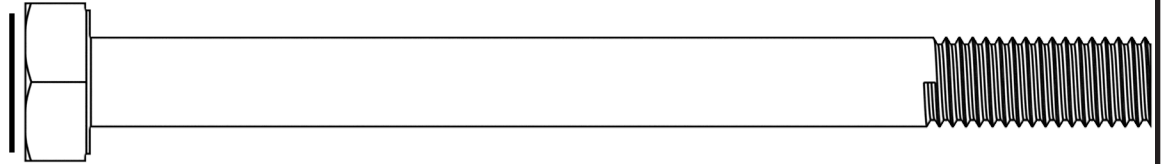

**M12
x160
BOLT**

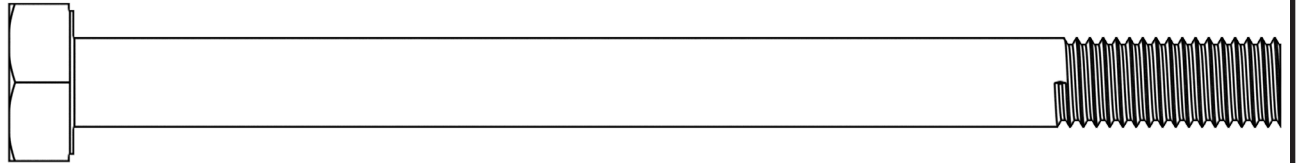

ASSEMBLY

STEP: 1

STEP PART GUIDE

#	PART NAME	QTY
1.	123-12-1	1
2.	123-12-2	2
3.	123-12-3	2
B.	M8x30 FULLY THREADED BOLT	2
F.	M8 WASHER	2

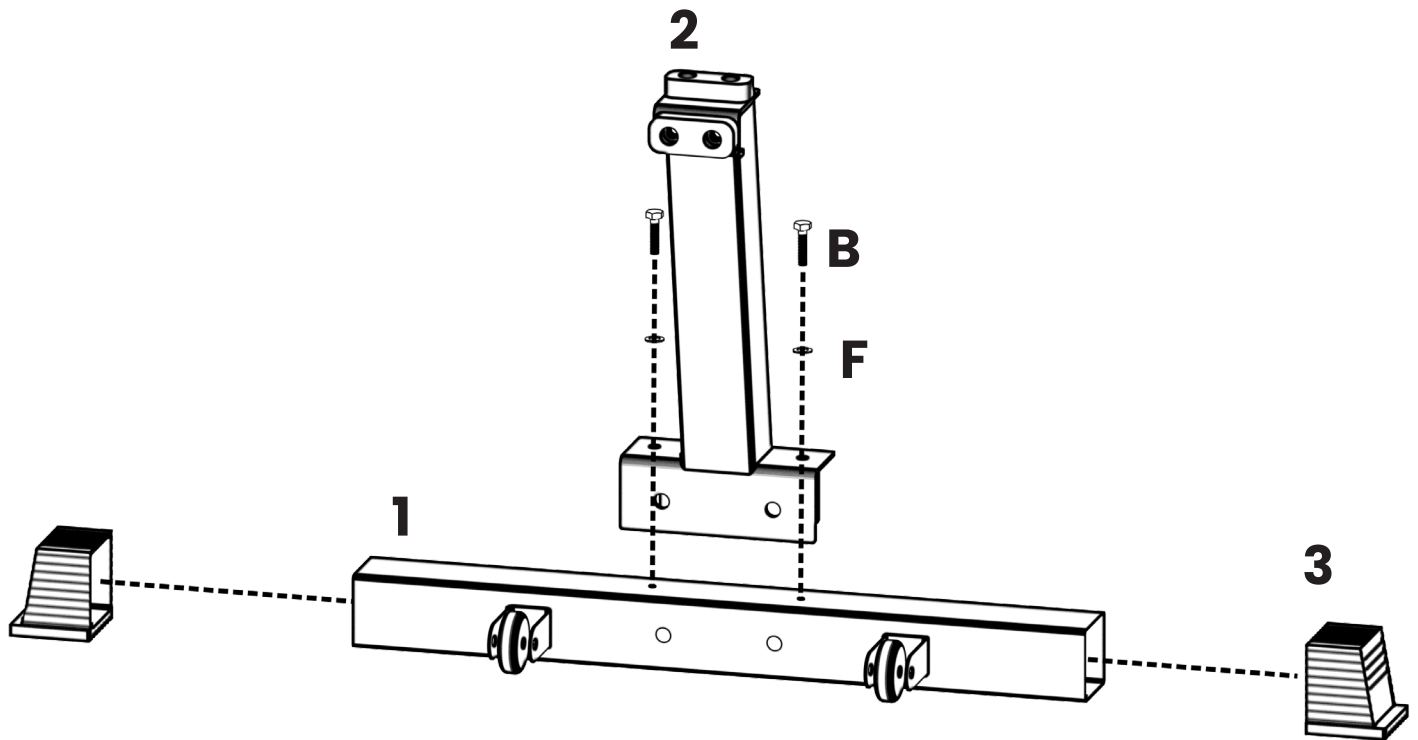

ASSEMBLY

STEP: 2

STEP PART GUIDE

#	PART NAME	QTY
4.	123-12-4	1
5.	123-12-5	1
6.	123-12-6	2
C.	M10x80 FULLY THREADED BOLT	6
G.	M10 WASHER	12
I.	M10 NUT	6

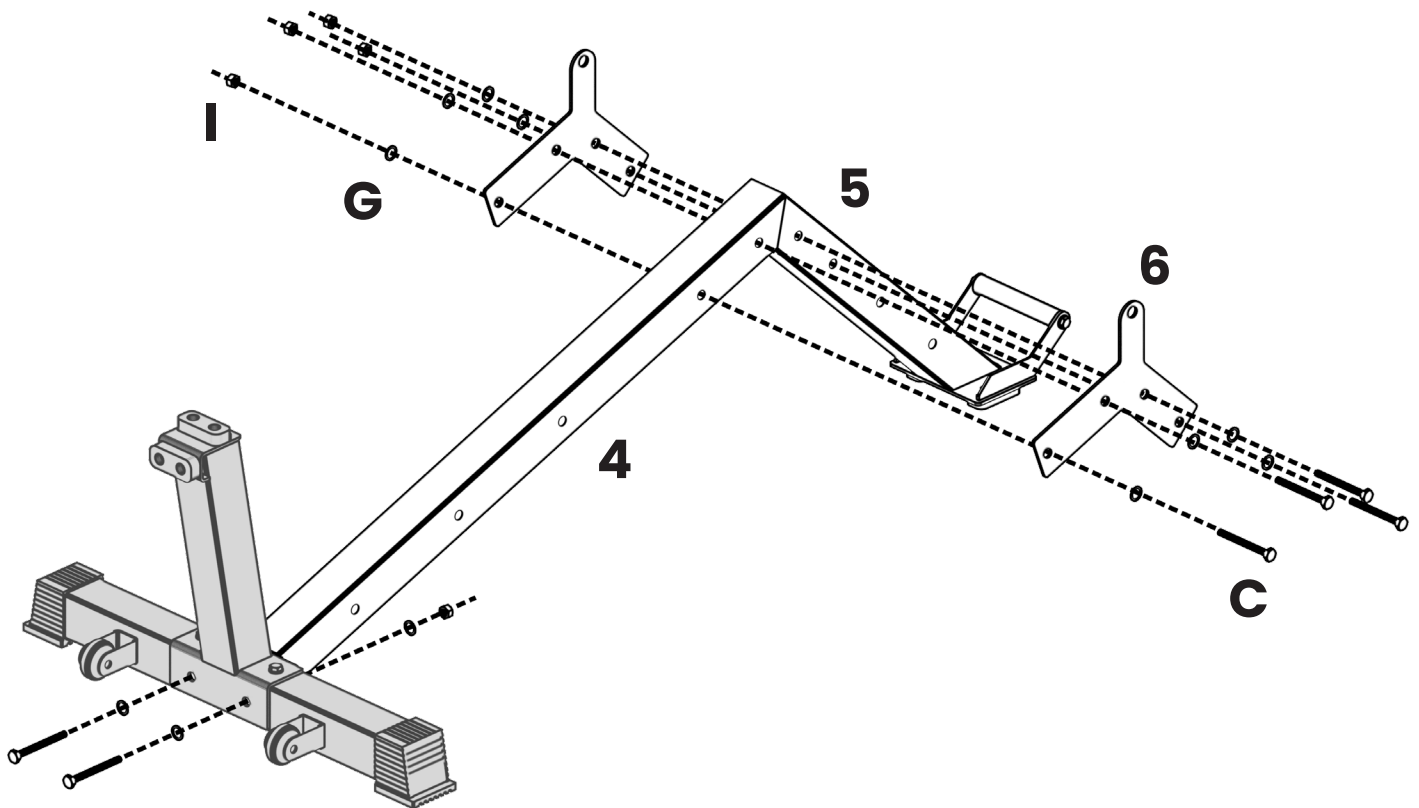

ASSEMBLY

STEP: 3

STEP PART GUIDE

#	PART NAME	QTY
7.	123-12-7	1
8.	123-12-8	1
C.	M10x80 PARTIALLY THREADED BOLTS	5
G.	M10 WASHERS	10
I.	M10 NUTS	5

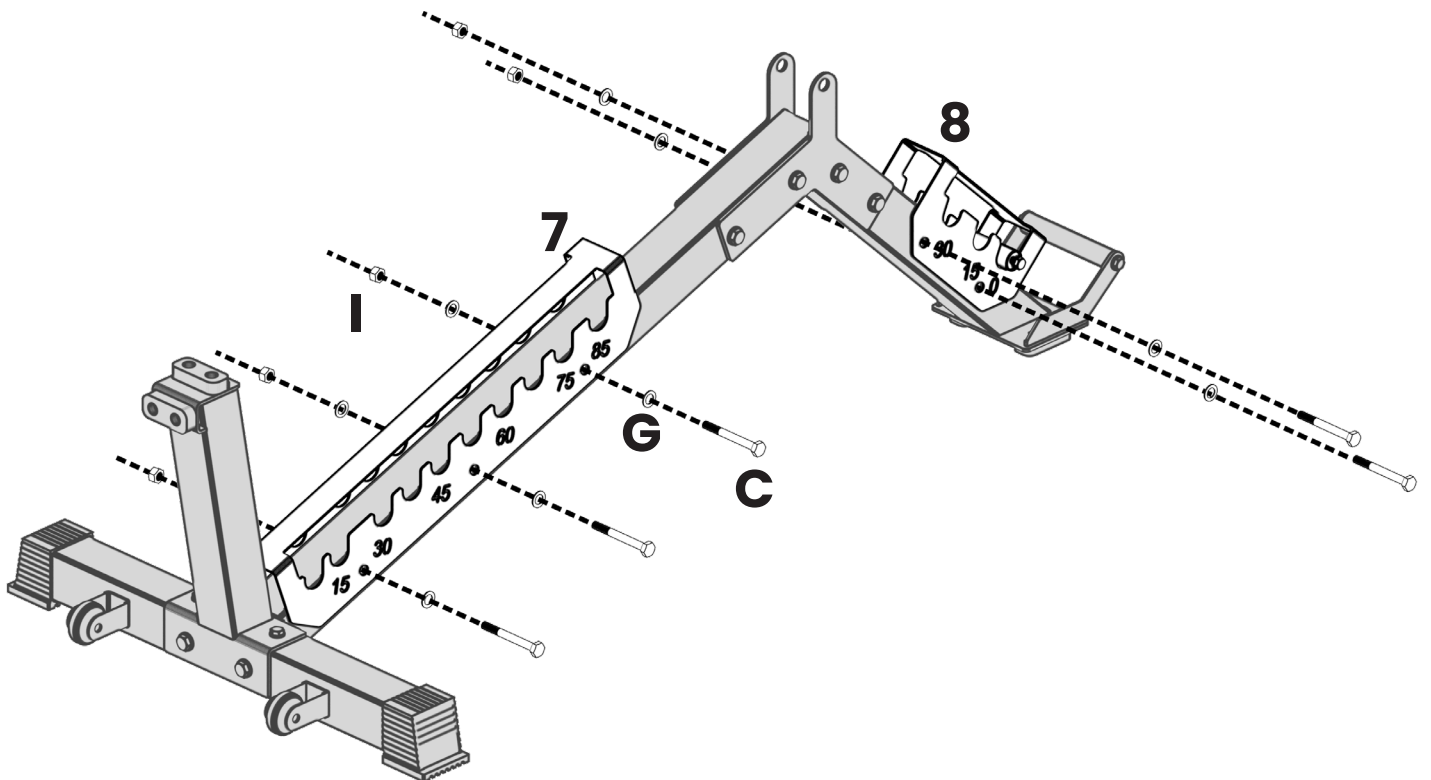

ASSEMBLY

STEP: 4

STEP PART GUIDE

#	PART NAME	QTY
9.	123-12-9	1
10.	123-12-10	1
A.	M8x20 FULLY THREADED BOLT	4
F.	M8 WASHER	4

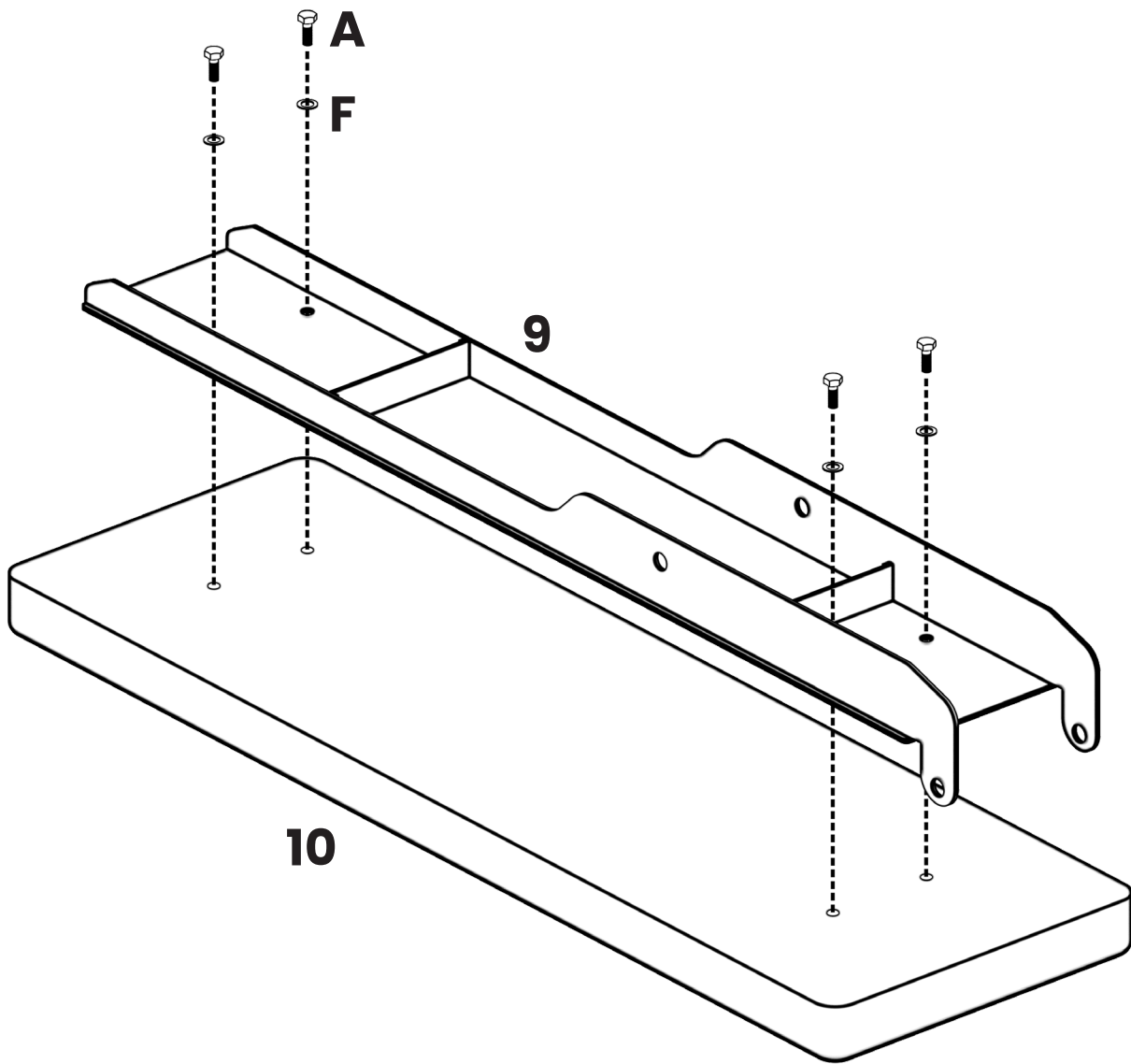

ASSEMBLY

STEP: 5

STEP PART GUIDE

#	PART NAME	QTY
11.	123-12-11	1
12.	123-12-12	1
A.	M8x20 FULLY THREADED BOLT	4
F.	M8 WASHER	4

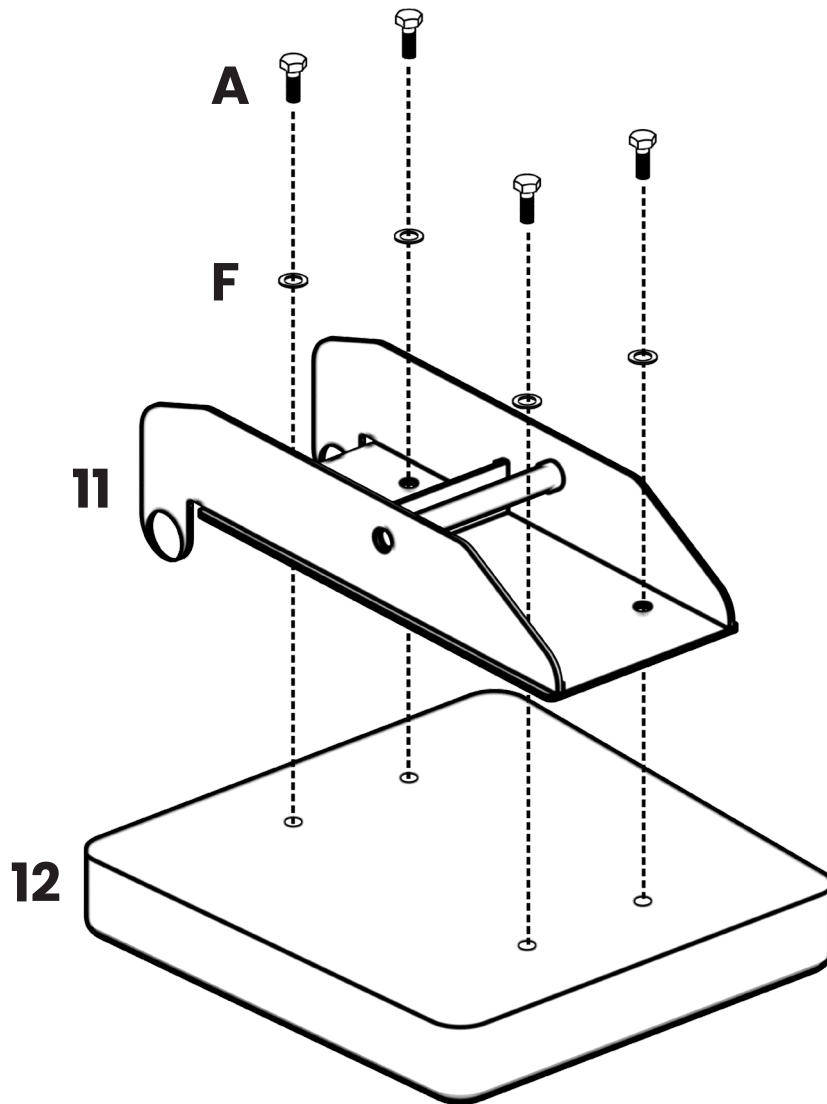

ASSEMBLY

STEP: 6-A

STEP PART GUIDE

#	PART NAME	QTY
-	ASSEMBLY FROM STEP 4	-
-	ASSEMBLY FROM STEP 5	-
13.	123-12-14	1

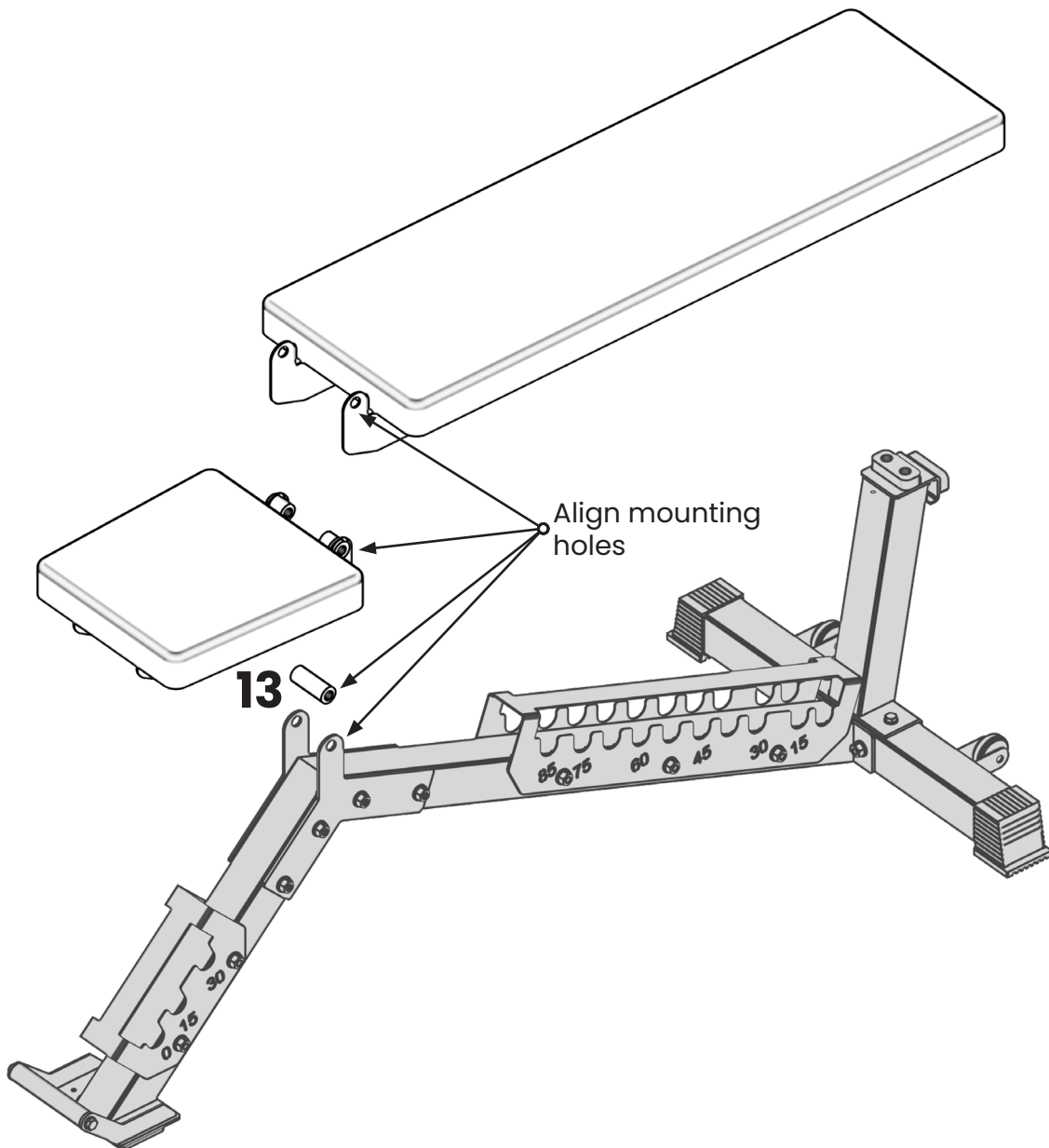

ASSEMBLY

STEP: 6-B

STEP PART GUIDE

#	PART NAME	QTY
E.	M12x160 FULLY THREADED BOLT	1
H.	M12 WASHER	2
J.	M12 NUT	1

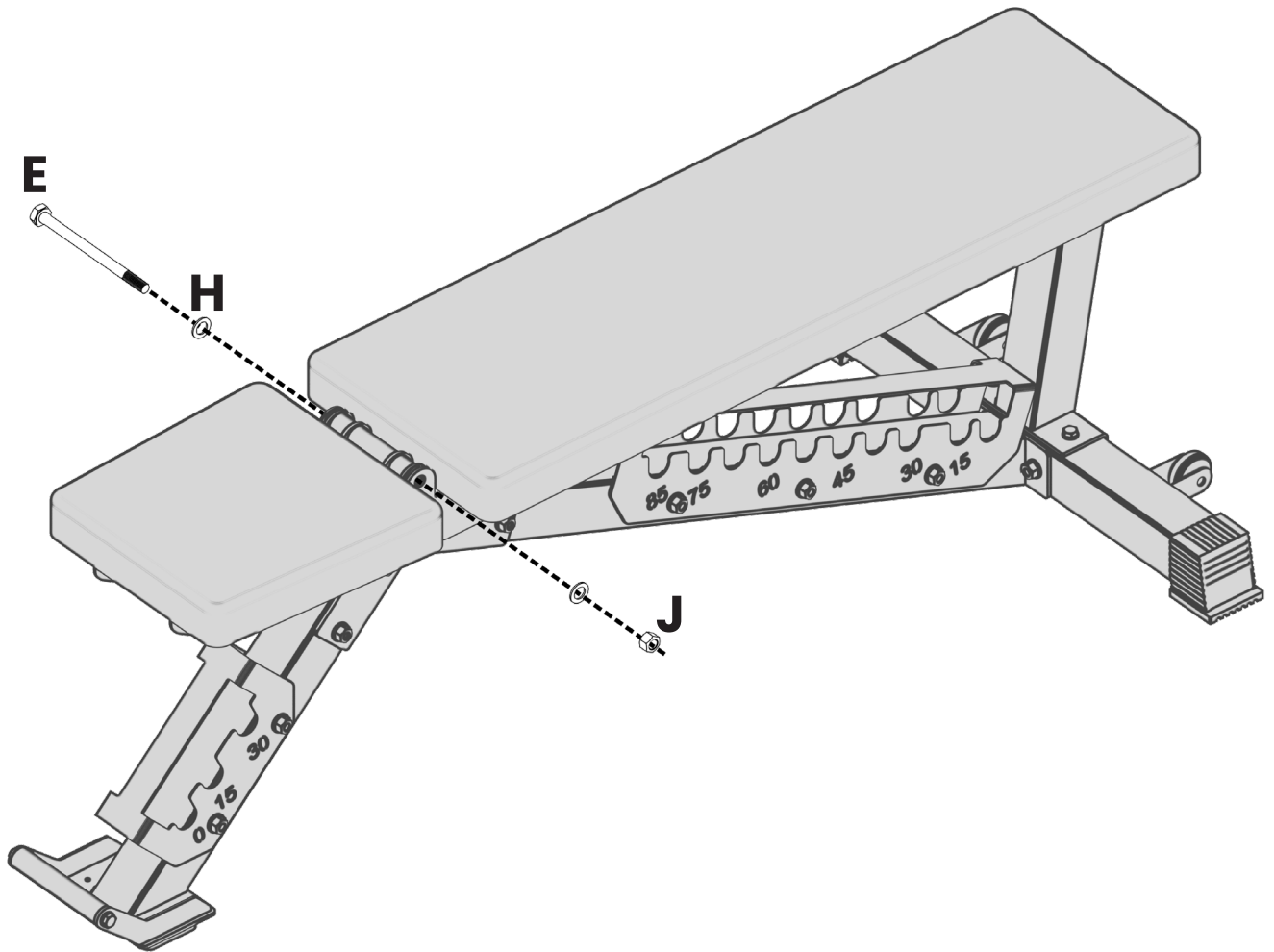

ASSEMBLY

STEP: 7-A

STEP PART GUIDE

#	PART NAME	QTY
14.	123-12-14	1
15.	123-12-15	3
B.	M8X30 FULLY THREADED BOLT	2
D.	M12X160 PARTIALLY THREADED BOLT	4
F.	M8 WASHER	1
H.	M12 WASHER	1
J.	M12 NUT	1

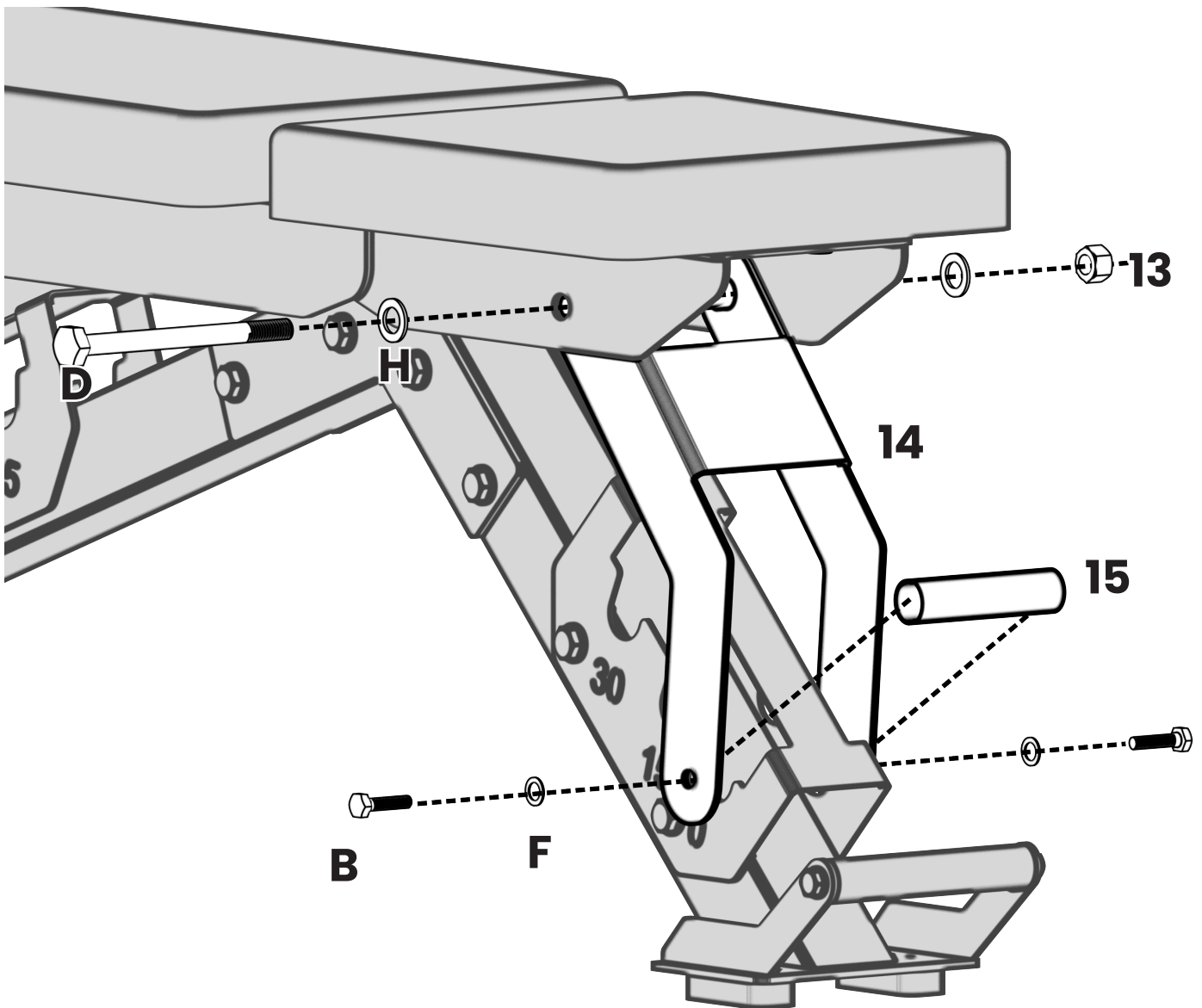

ASSEMBLY

STEP: 7-B

STEP PART GUIDE

#	PART NAME	QTY
16.	123-12-16	1
17.	123-12-17	3
B.	M8X30 FULLY THREADED BOLT	2
E.	M12X160 PARTIALLY THREADED BOLT	4
F.	M8 WASHER	1
H.	M12 WASHER	1
J.	M12 NUT	1

