

**SYNERGEE<sup>®</sup>**

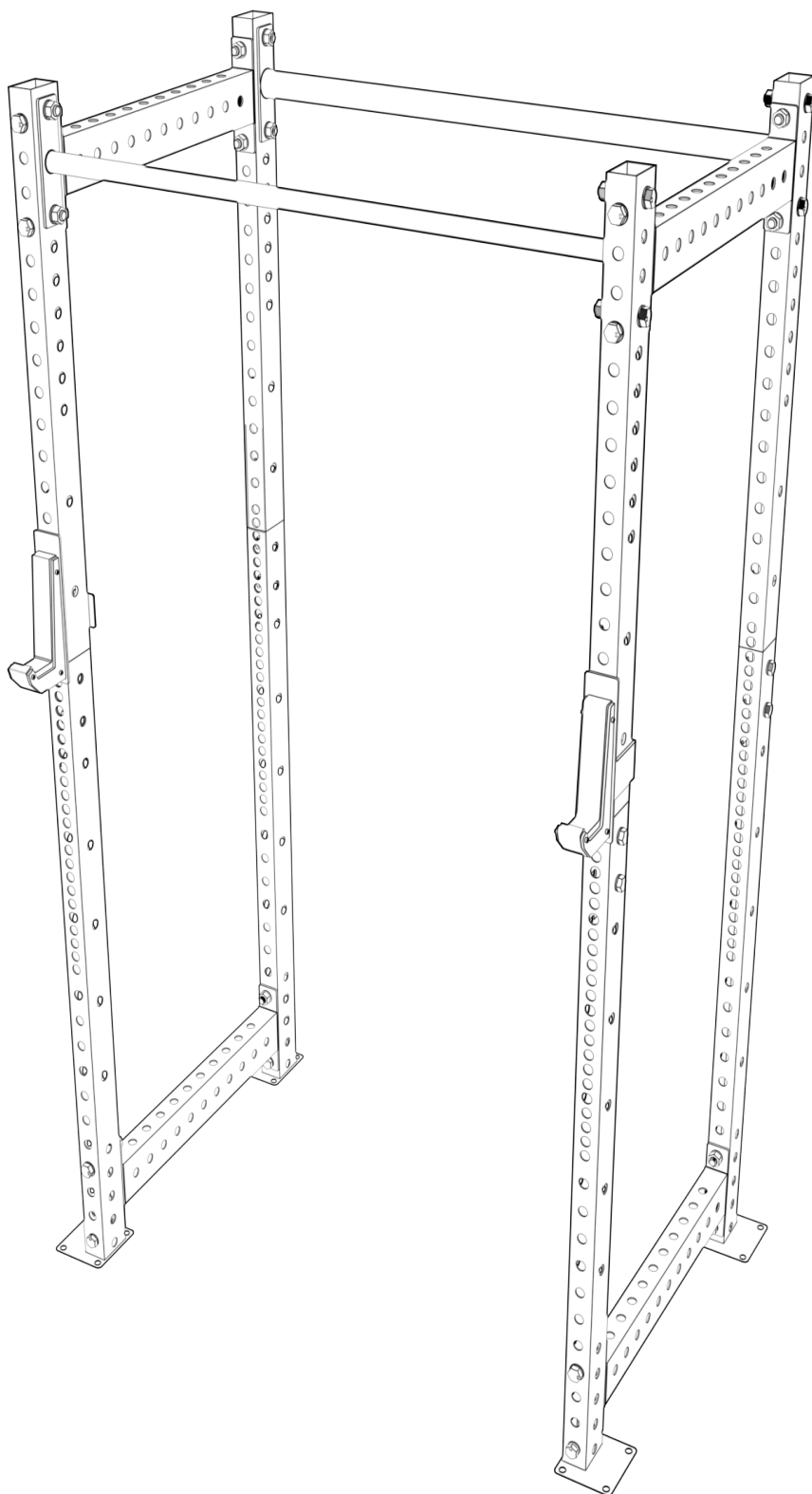





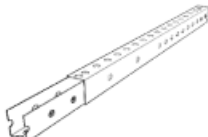
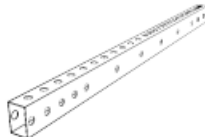
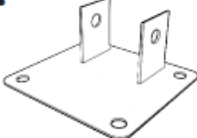
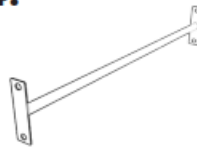
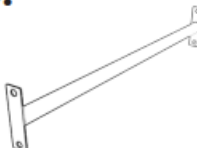

# POWER RACK

## SF2300 SERIES

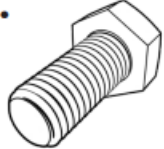

# PARTS LIST

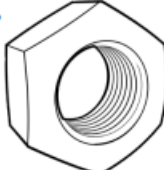
IF ANY PIECES ARE MISSING, PLEASE CONTACT US IMMEDIATELY:  
HELLO@SYNERGEEFITNESS.COM OR 1.855.217.7136

<p><b>1.</b>  QTY x4</p> <p>2300-01-1</p>	<p><b>2.</b>  QTY x4</p> <p>2300-01-2</p>	<p><b>3.</b>  QTY x4</p> <p>2300-01-3</p>	<p><b>4.</b>  QTY x1</p> <p>2300-05</p>	<p><b>5.</b>  QTY x1</p> <p>2300-06</p>
<p><b>6.</b>  QTY x16</p> <p>M14 WASHER</p>	<p><b>7.</b>  QTY x38</p> <p>M16 WASHER</p>	<p><b>8.</b>  QTY x12</p> <p>M16x110mm HEX SCREW</p>	<p><b>9.</b>  QTY x8</p> <p>M16x80mm HEX SCREW</p>	<p><b>10.</b>  QTY x8</p> <p>M14x30mm HEX SCREW</p>
<p><b>11.</b>  QTY x8</p> <p>M14x16mm HEX SCREW</p>	<p><b>12.</b>  QTY x8</p> <p>M16 NUT</p>	<p><b>13.</b>  QTY x2</p> <p>2300-07</p>	<p><b>14.</b>  QTY x16</p> <p>M6 EXPANSION SCREW</p>	

## PARTS DETERMINED BY PURCHASE:

**16"** POWER RACK

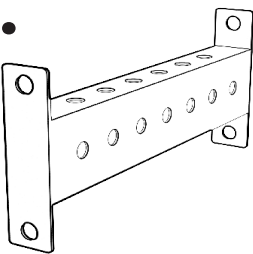
**15.**  QTY x4

2300-02

**24"** POWER RACK

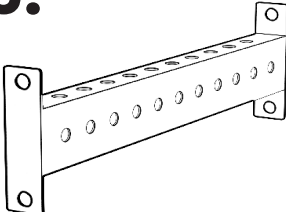
**16.**  QTY x4

2300-03

**36"** POWER RACK

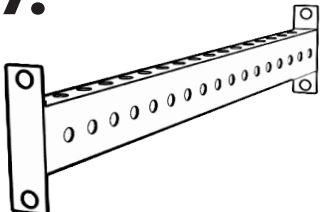
**17.**  QTY x4

2300-04

# HARDWARE SIZING CHART

**M16x110  
HEX SCREW**

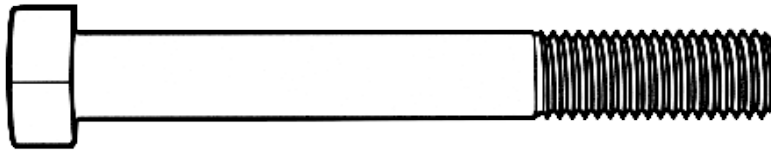

STEPS  
**2A-2C**

**M16x80  
HEX SCREW**

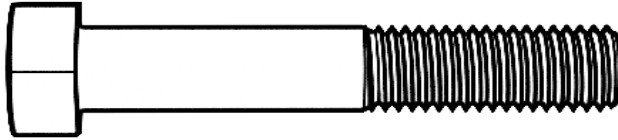

STEPS  
**4A-4C**

**M14x30  
HEX SCREW**

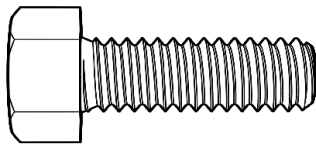

STEPS  
**3**

**M14x16  
HEX SCREW**

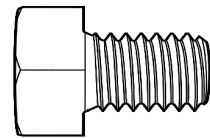

STEPS  
**1**

## WASHERS

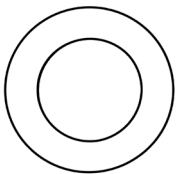

**M14 WASHERS**

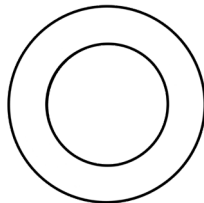

**M16 WASHERS**

## NUTS

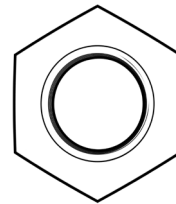

**M16 NUTS**

# ASSEMBLY

## STEP: 1

# STEP PART GUIDE

#	PART NAME	QTY
1.	2300-01-1	4
2.	2300-01-2	4
6.	M14 Washer	8
11.	M14x16mm Hex Screw	8

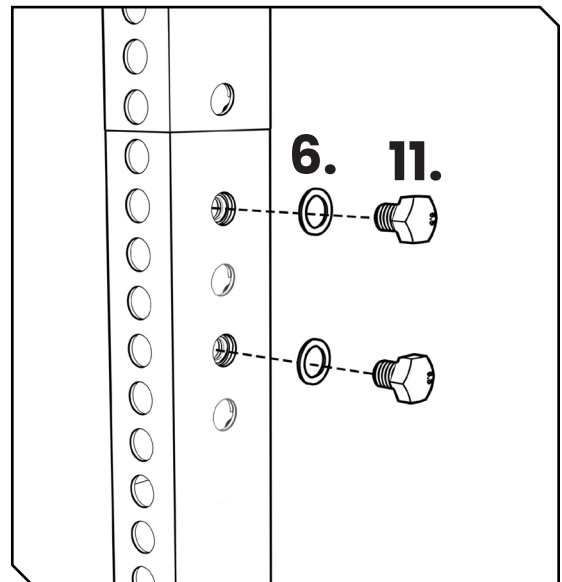
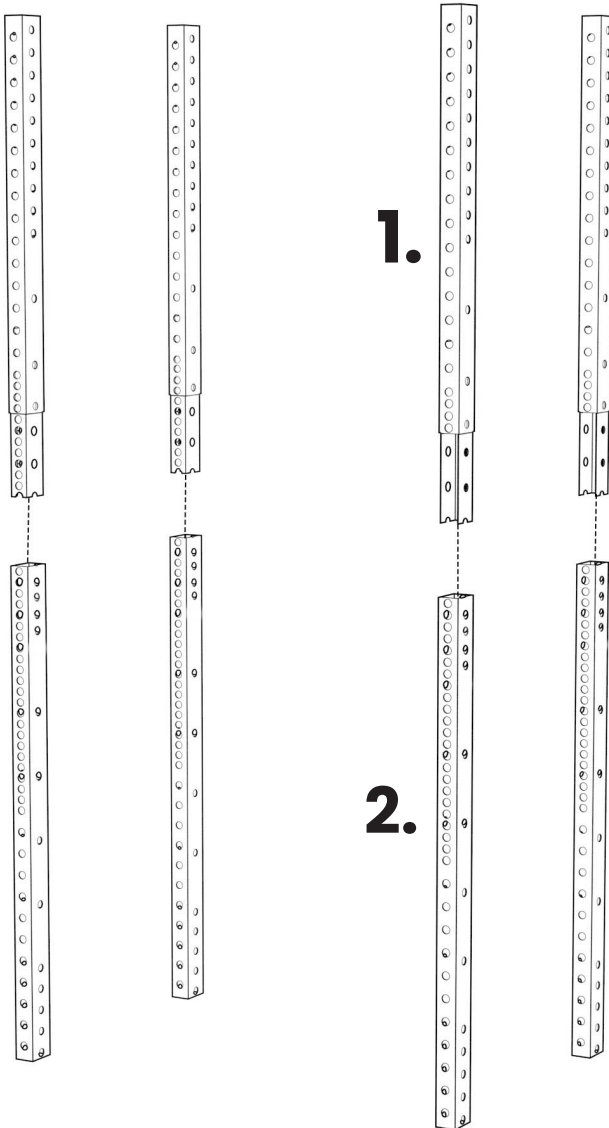

# ASSEMBLY

## STEP: 2A

# 16"

### STEP PART GUIDE

#	PART NAME	QTY
15.	2300-02	4
7.	M16 Washer	24
8.	M16x110mm Hex Screw	12
12.	M16 Nut	12

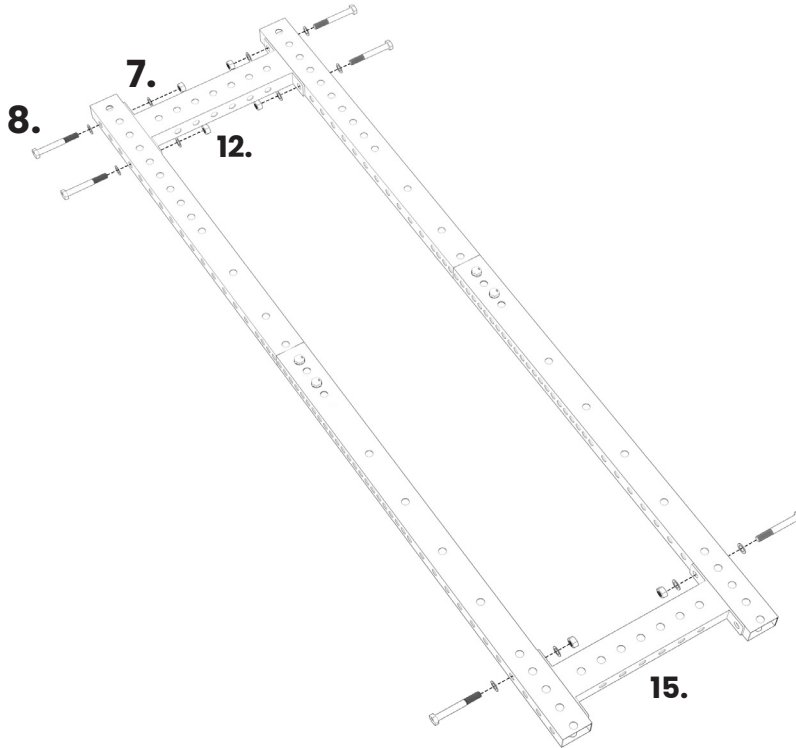

### TOP

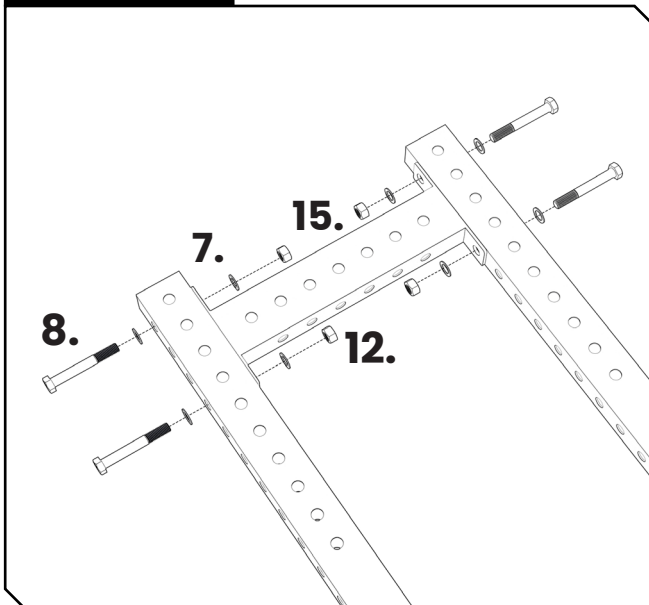

### BOTTOM

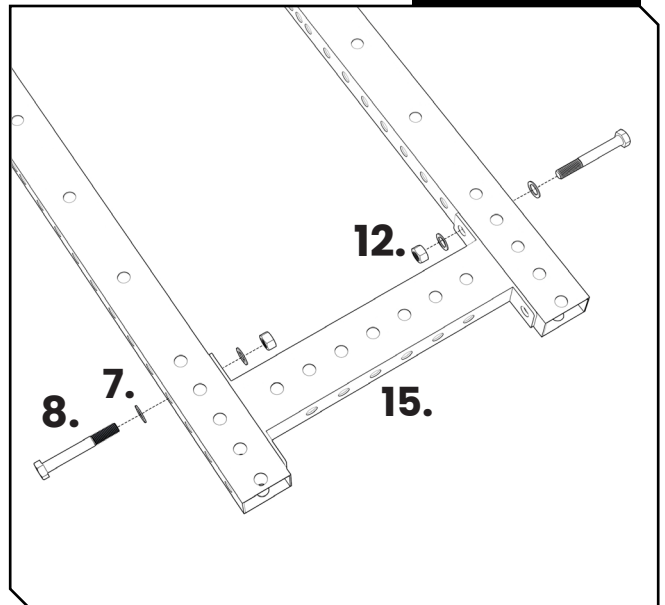

# ASSEMBLY

## STEP: 2B

# 24"

### STEP PART GUIDE

#	PART NAME	QTY
16.	2300-03	4
7.	M16 Washer	24
8.	M16x110mm Hex Screw	12
12.	M16 Nut	12

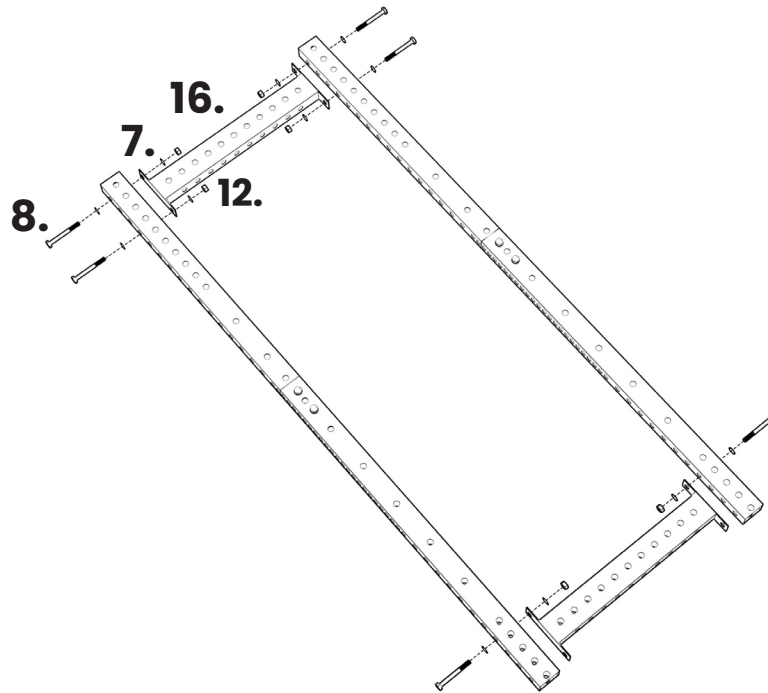

# x2

### TOP

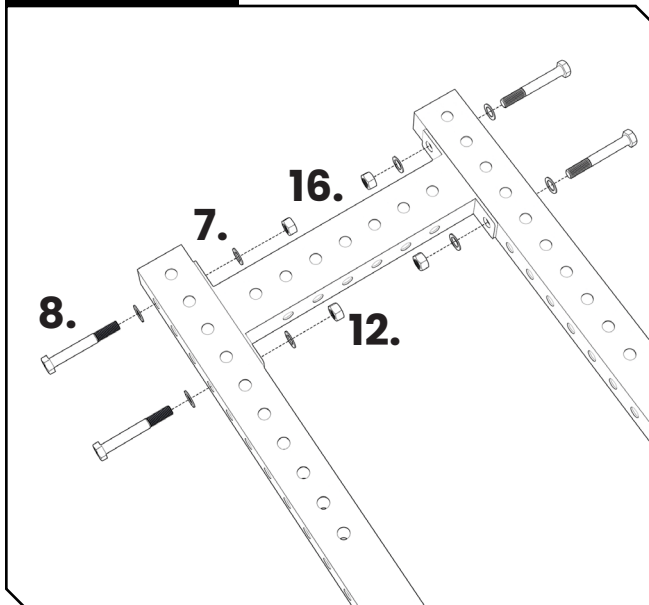

### BOTTOM

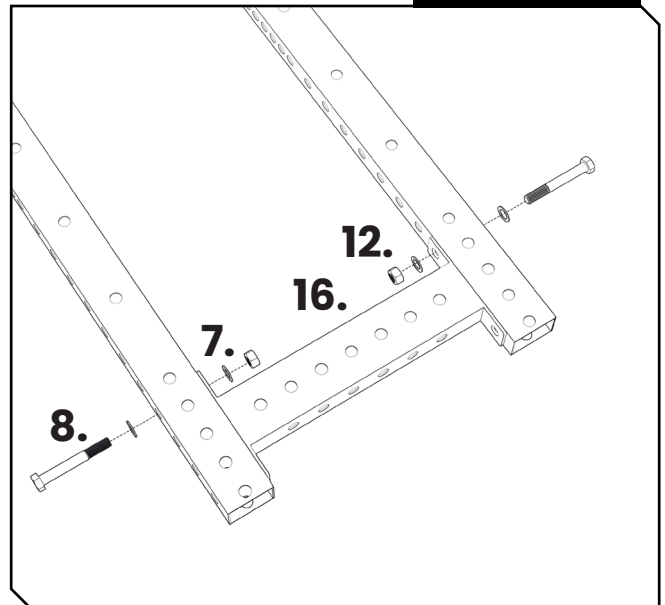

# ASSEMBLY

## STEP: 2C

# 36"

### STEP PART GUIDE

#	PART NAME	QTY
17.	2300-04	4
7.	M16 Washer	24
8.	M16x110mm Hex Screw	12
12.	M16 Nut	12

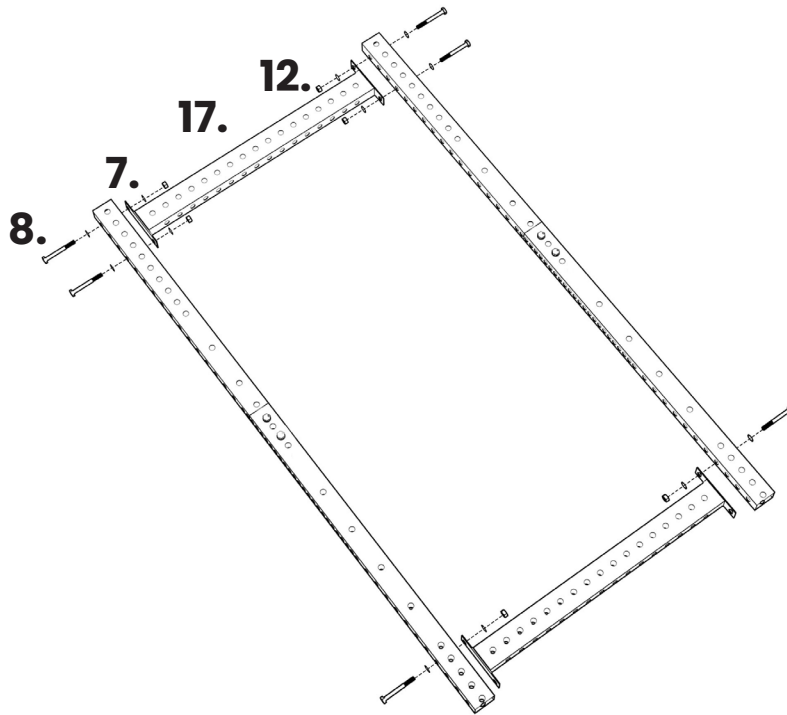

**TOP**

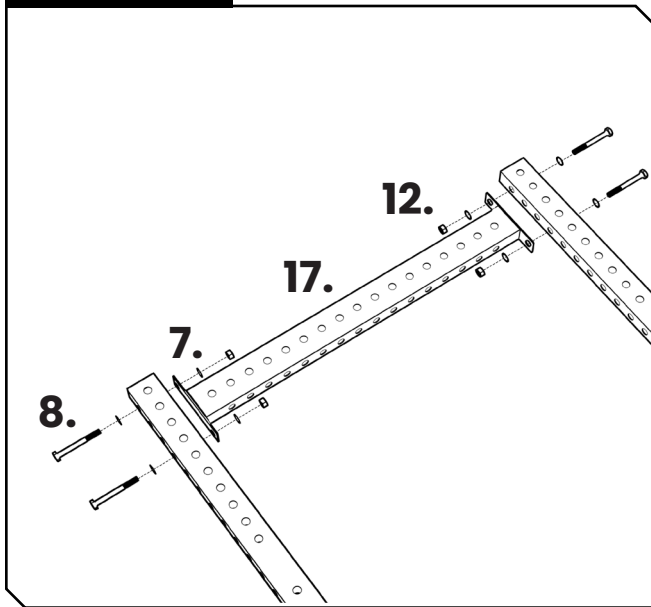

**BOTTOM**

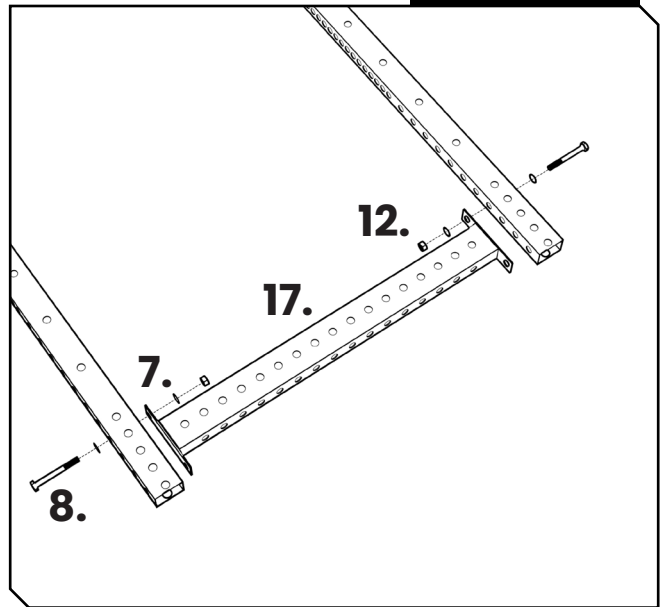

# ASSEMBLY

## STEP: 3

# STEP PART GUIDE

#	PART NAME	QTY
3.	2300-01-3	4
6.	M14 Washer	8
10.	M14x30mm Hex Screw	8

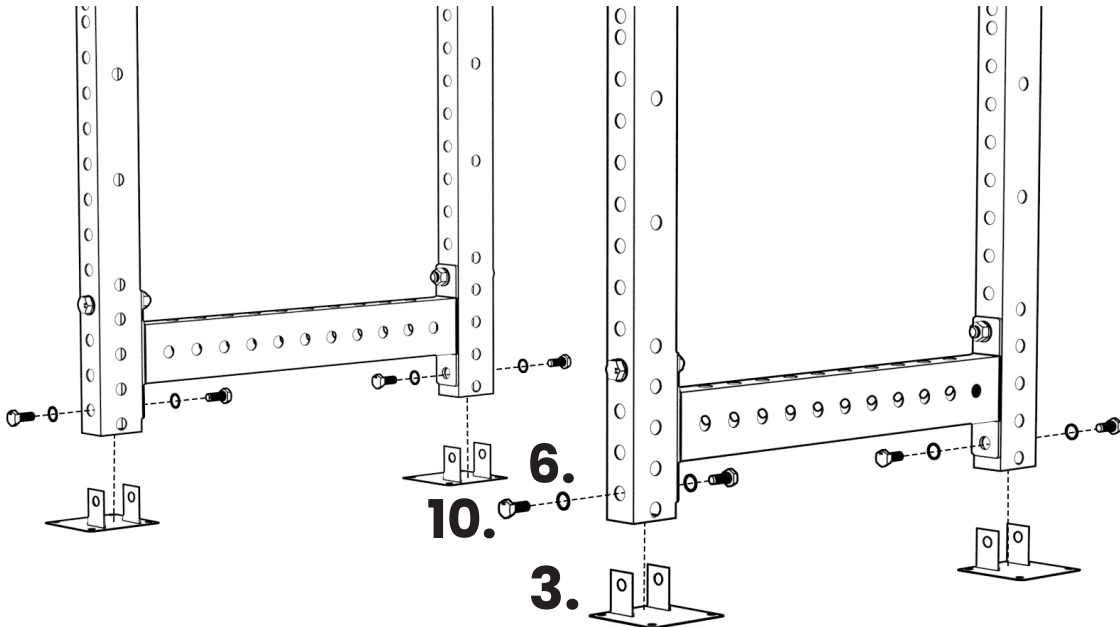

### STEP 3A

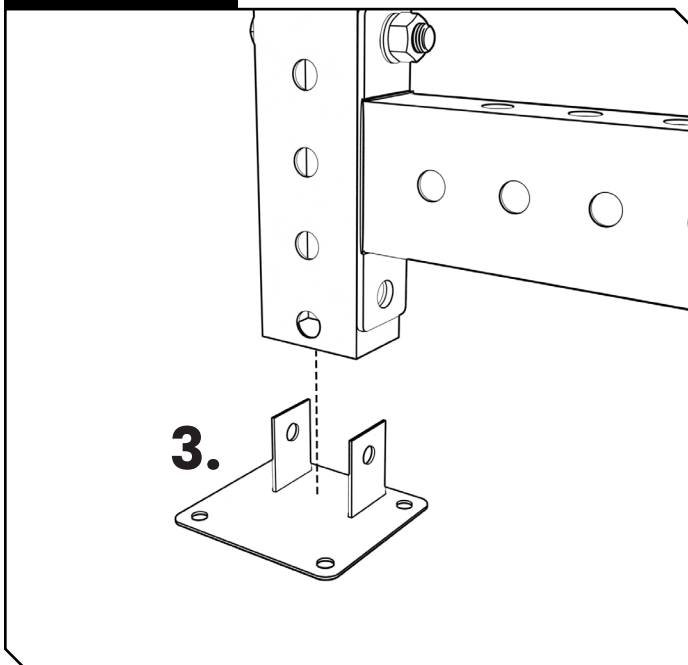

### STEP 3B

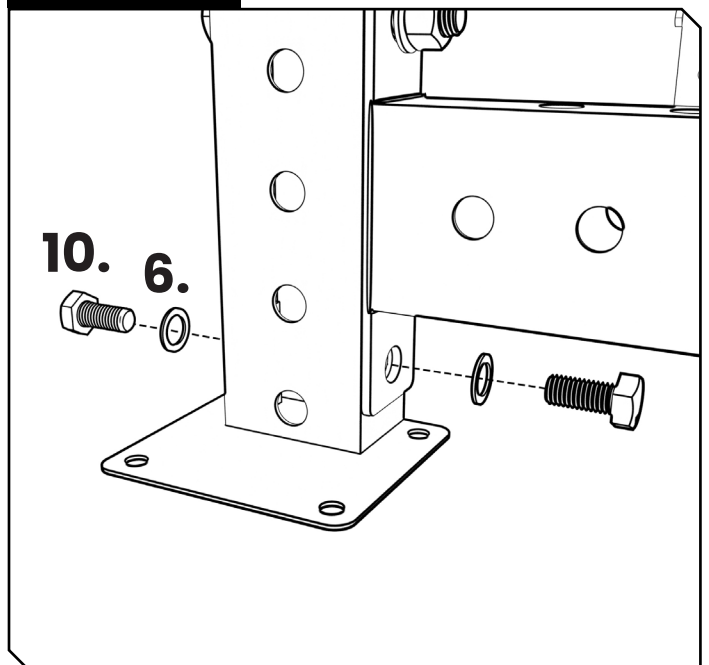



# ASSEMBLY

## STEP: 4A

# 16"



**SECURE FEET POINTING  
OUTWARDS**



## STEP PART GUIDE

#	PART NAME	QTY
4.	2300-05	1
5.	2300-06	1
7.	M16 Washer	16
9.	M16x80mm Hex Screw	8
12.	M16 Nut	8

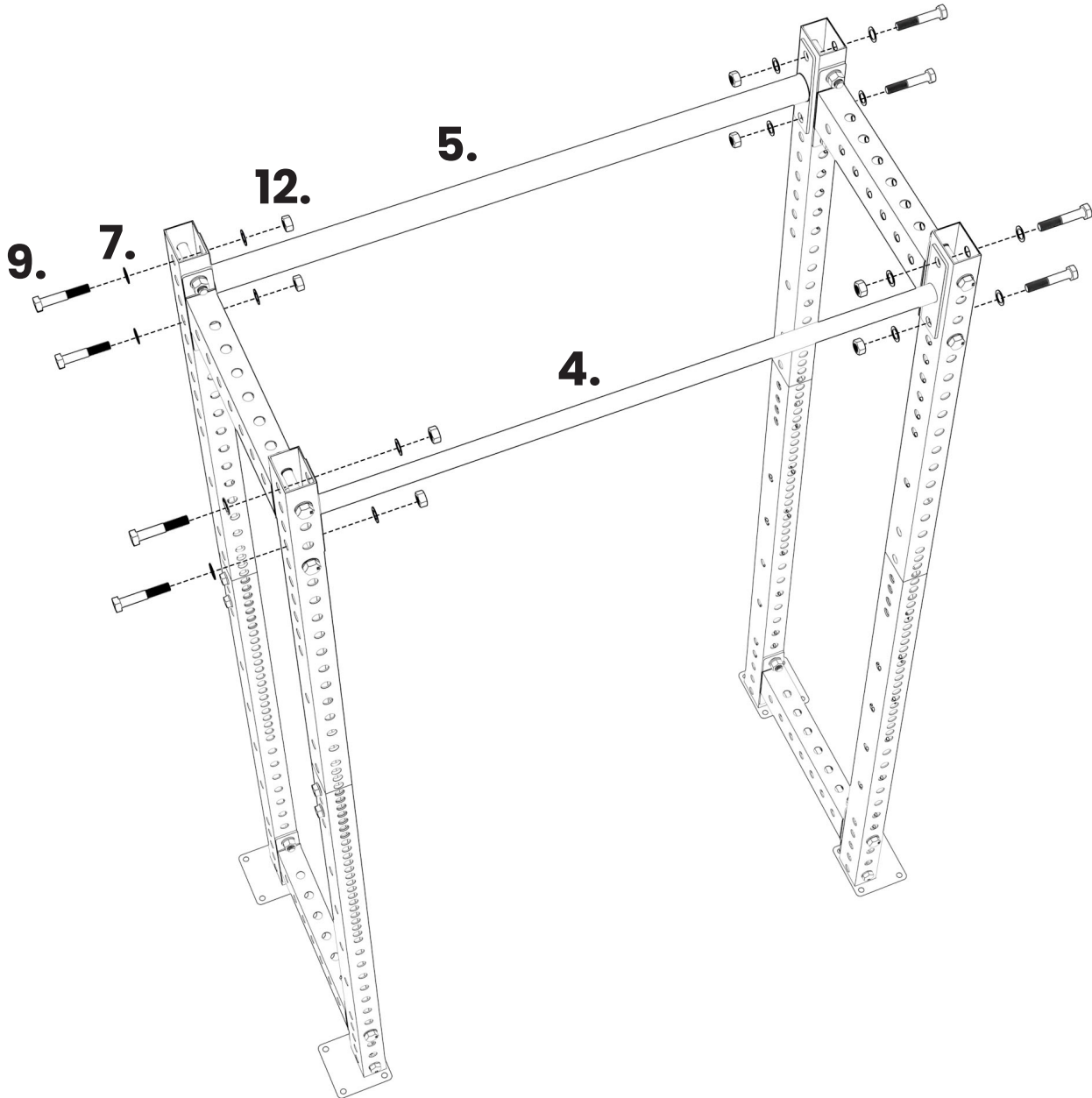

# ASSEMBLY

## STEP: 4B

# 24"



**SECURE FEET POINTING  
OUTWARDS**



## STEP PART GUIDE

#	PART NAME	QTY
4.	2300-05	1
5.	2300-06	1
7.	M16 Washer	16
9.	M16x80mm Hex Screw	8
12.	M16 Nut	8

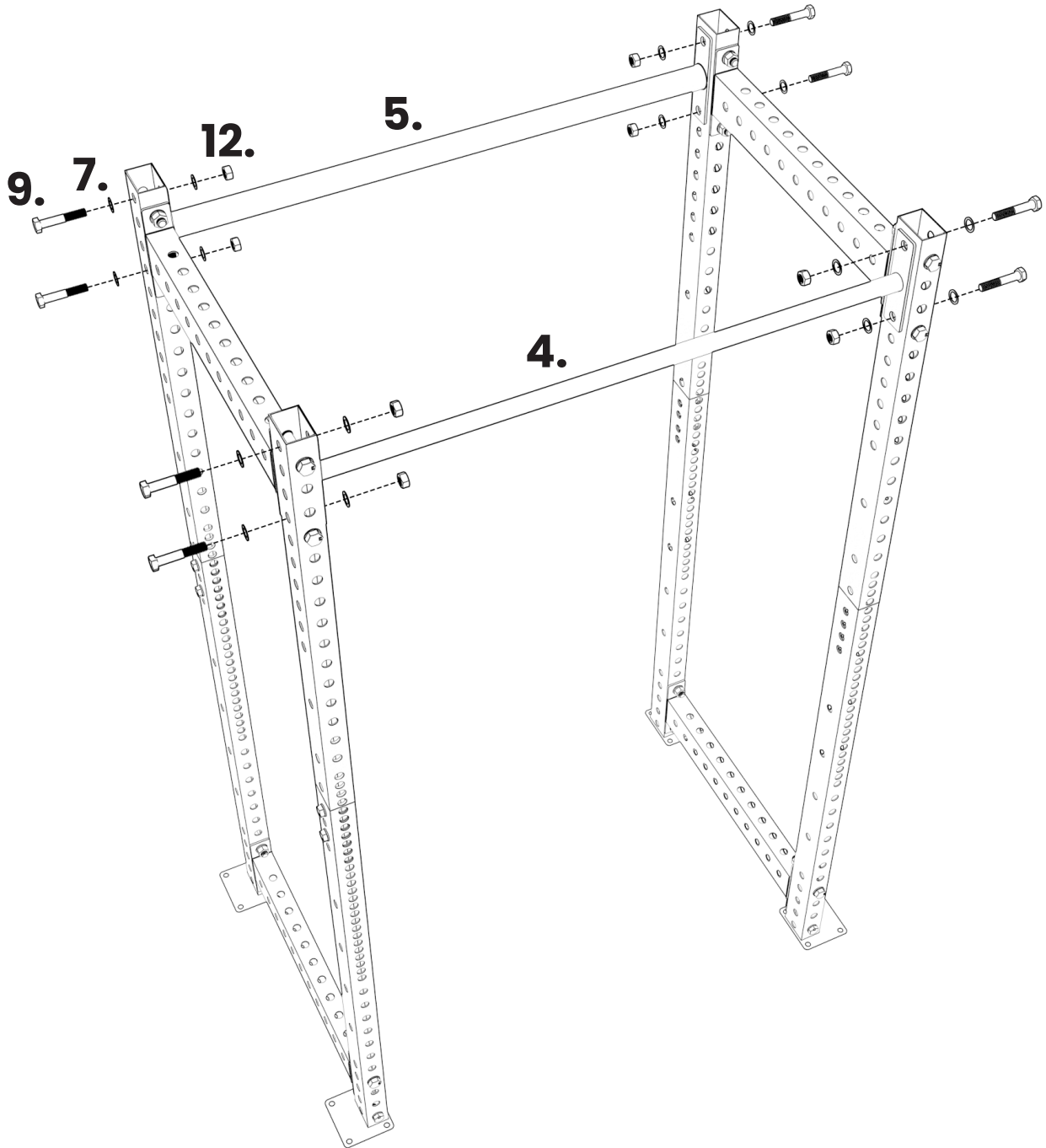

# ASSEMBLY

## STEP: 4C

# 36"



**SECURE FEET POINTING  
OUTWARDS**



## STEP PART GUIDE

#	PART NAME	QTY
4.	2300-05	1
5.	2300-06	1
7.	M16 Washer	16
9.	M16x80mm Hex Screw	8
12.	M16 Nut	8

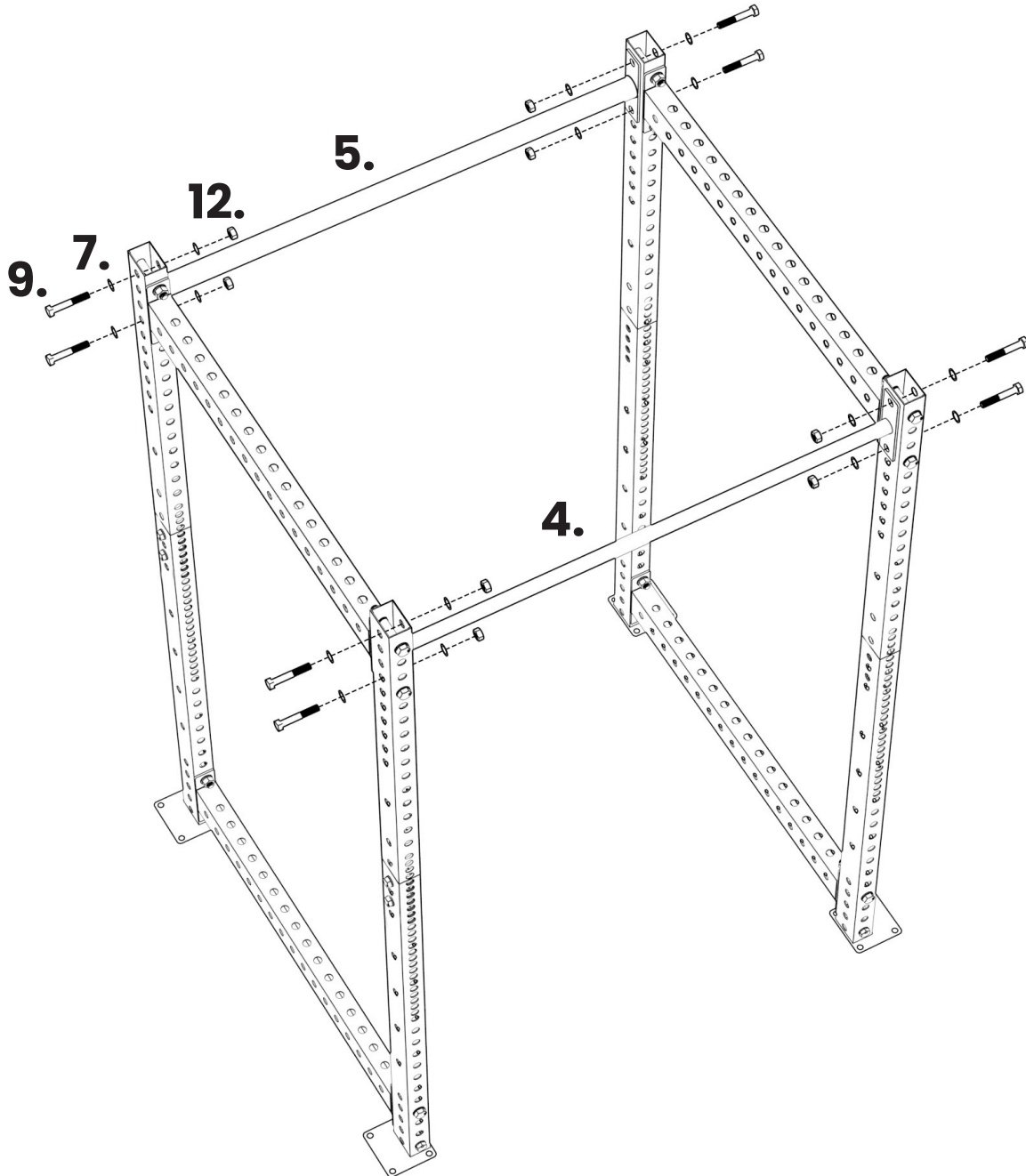

# ASSEMBLY

## STEP: 5

# STEP PART GUIDE

#	PART NAME	QTY
13.	2300-07	2

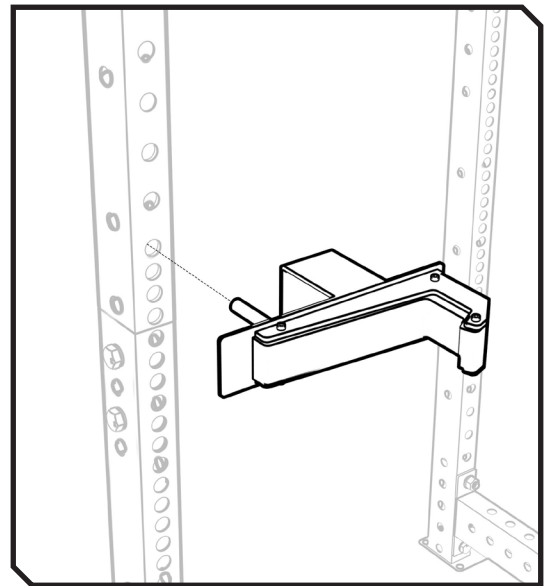
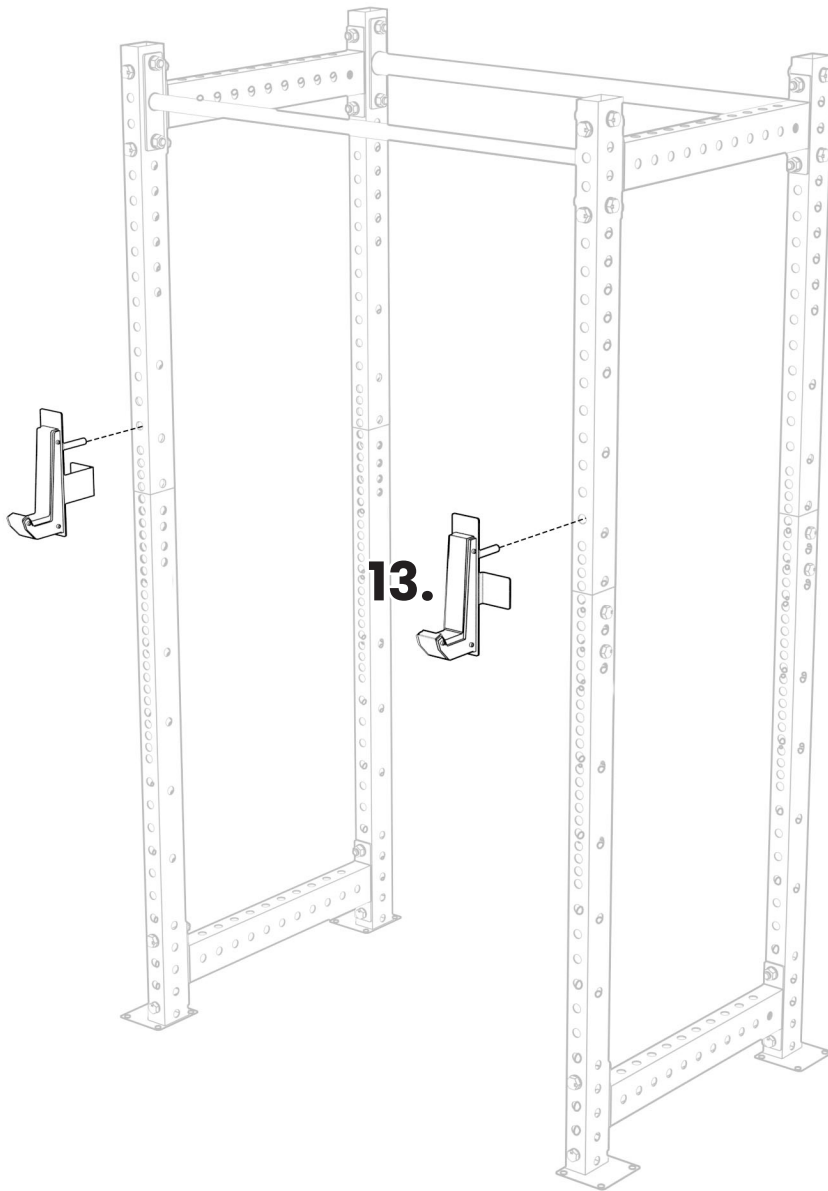

# ASSEMBLY

## STEP: 6

# STEP PART GUIDE

#	PART NAME	QTY
14.	M6 Expansion Screw	16

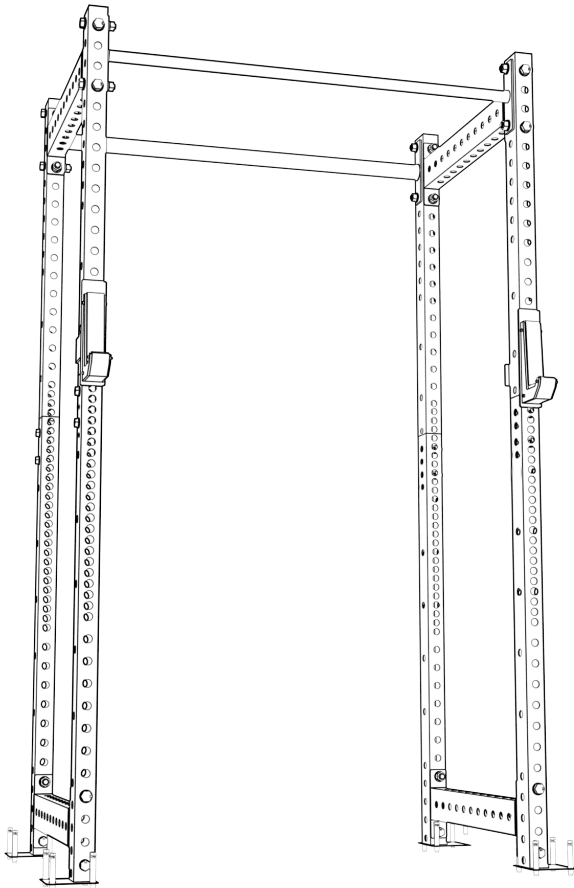

## ! IMPORTANT

**ENSURE RACK IS LEVEL TO THE FLOOR BY MEASURING TOP AND BOTTOM SPACING IS EQUAL.**

