

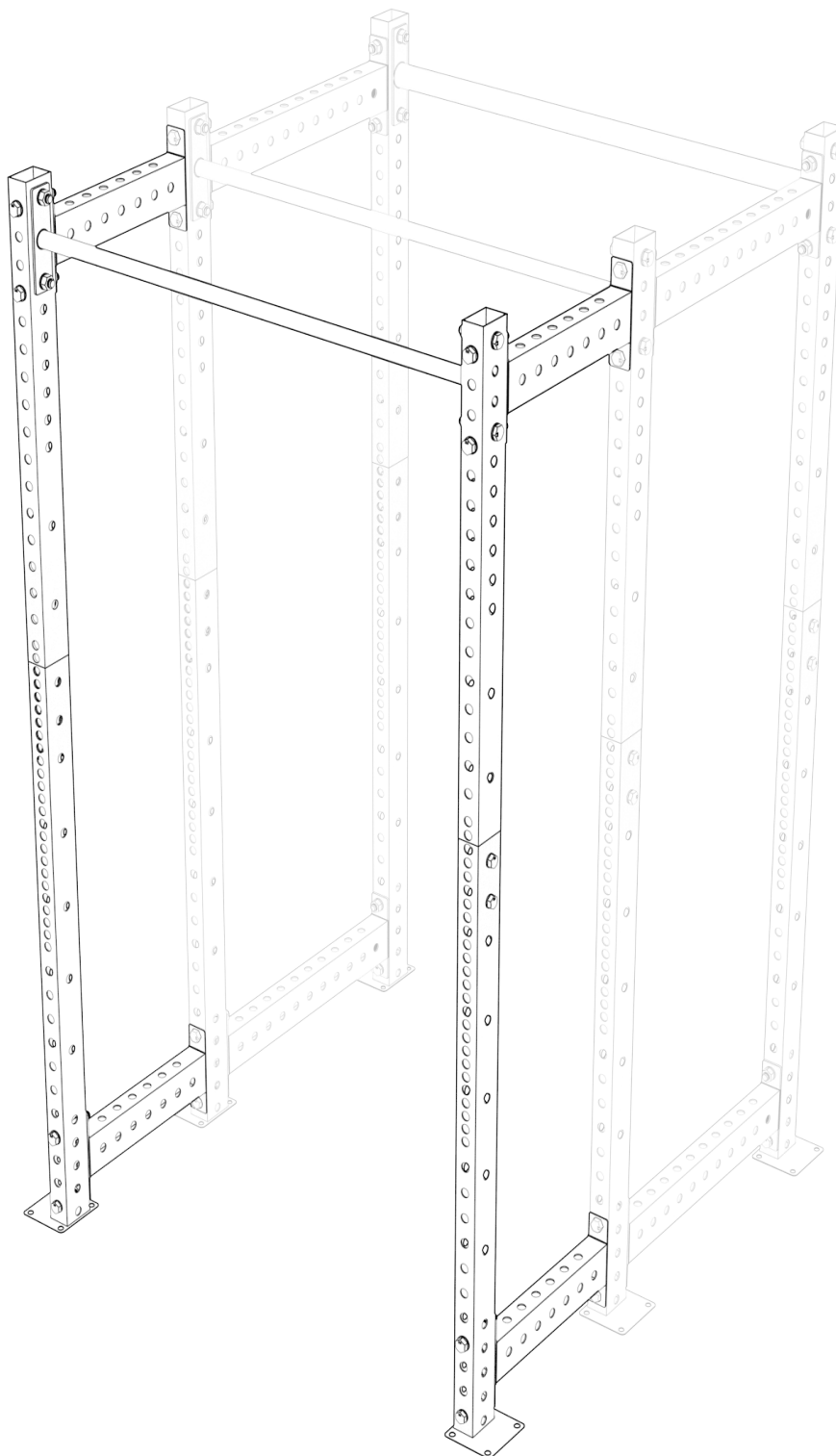

**SYNERGEE<sup>®</sup>**

# POWER RACK EXTENSION SF2300 SERIES

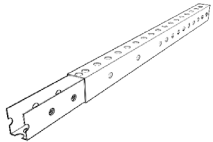
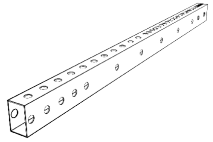
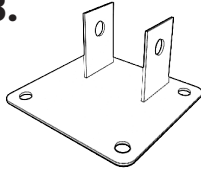
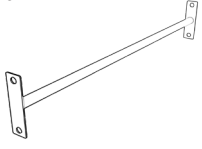
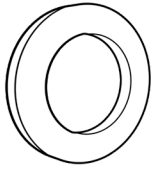
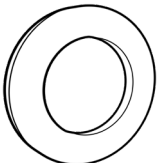

# PARTS LIST

IF ANY PIECES ARE MISSING, PLEASE CONTACT US IMMEDIATELY:  
HELLO@SYNERGEEFITNESS.COM OR 1.855.217.7136

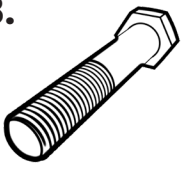
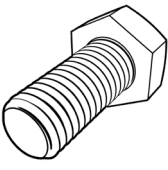
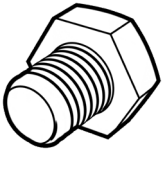
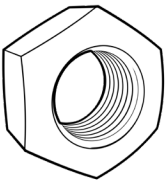
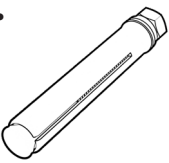
<p><b>1.</b>  QTY x2</p> <p><b>2300-01-1</b></p>	<p><b>2.</b>  QTY x2</p> <p><b>2300-01-2</b></p>	<p><b>3.</b>  QTY x2</p> <p><b>2300-01-3</b></p>	<p><b>4.</b>  QTY x1</p> <p><b>2300-05</b></p>	<p><b>5.</b>  QTY x8</p> <p><b>M14 WASHER</b></p>
<p><b>6.</b>  QTY x20</p> <p><b>M16 WASHER</b></p>	<p><b>7.</b>  QTY x6</p> <p><b>M16x110mm HEX SCREW</b></p>	<p><b>8.</b>  QTY x4</p> <p><b>M16x80mm HEX SCREW</b></p>	<p><b>9.</b>  QTY x4</p> <p><b>M14x30mm HEX SCREW</b></p>	<p><b>10.</b>  QTY x4</p> <p><b>M14x16mm HEX SCREW</b></p>
<p><b>11.</b>  QTY x10</p> <p><b>M16 NUT</b></p>	<p><b>12.</b>  QTY x8</p> <p><b>M6 EXPANSION SCREW</b></p>			

## PARTS DETERMINED BY PURCHASE:

**16" POWER RACK**

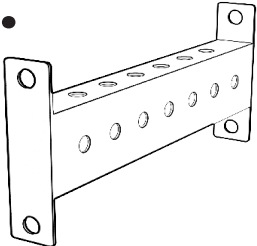
**13.**  QTY x4

**2300-02**

**24" POWER RACK**

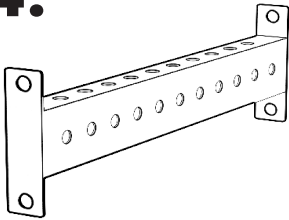
**14.**  QTY x4

**2300-03**

**36" POWER RACK**

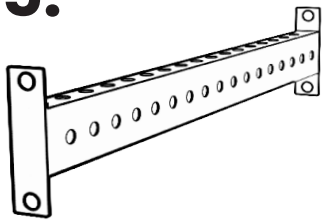
**15.**  QTY x4

**2300-04**

# HARDWARE SIZING CHART

**M16x110  
HEX SCREW**

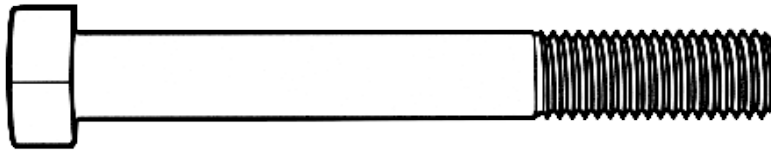

STEPS  
**2A-2C**

**M16x80  
HEX SCREW**

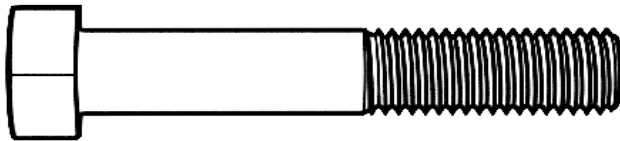

STEPS  
**4A-4C**

**M14x30  
HEX SCREW**

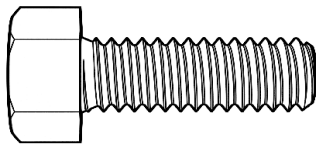

STEPS  
**3**

**M14x16  
HEX SCREW**

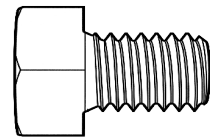

STEPS  
**1**

## WASHERS

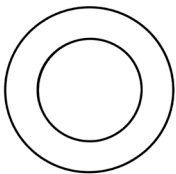

**M14 WASHERS**

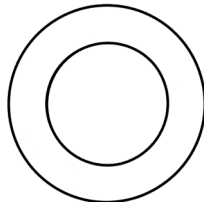

**M16 WASHERS**

# ASSEMBLY

## STEP: 1

### STEP PART GUIDE

#	PART NAME	QTY
1.	2300-01-1	2
2.	2300-01-2	2
5.	M14 Washer	4
10.	M14x16mm Hex Screw	4

1.

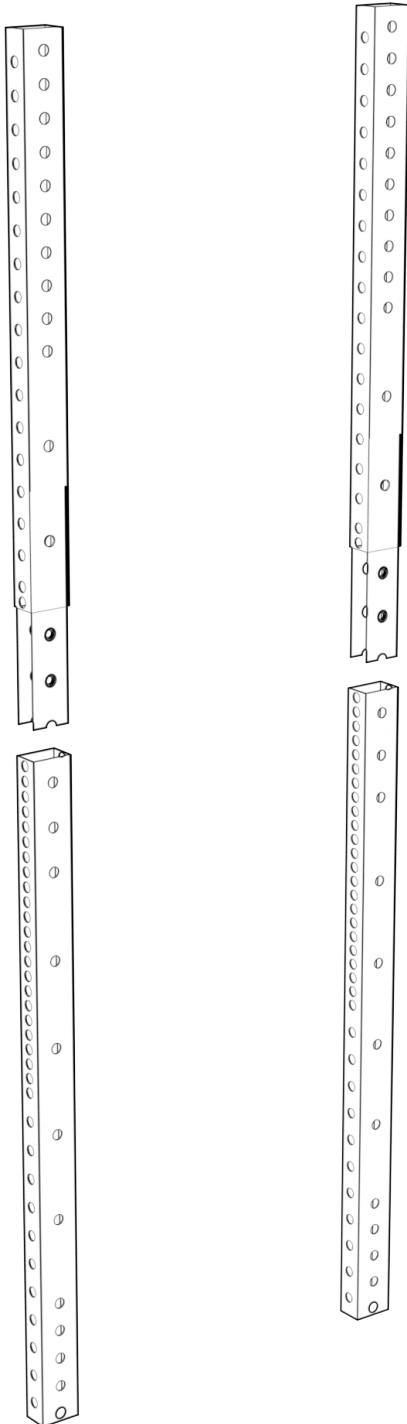

2.

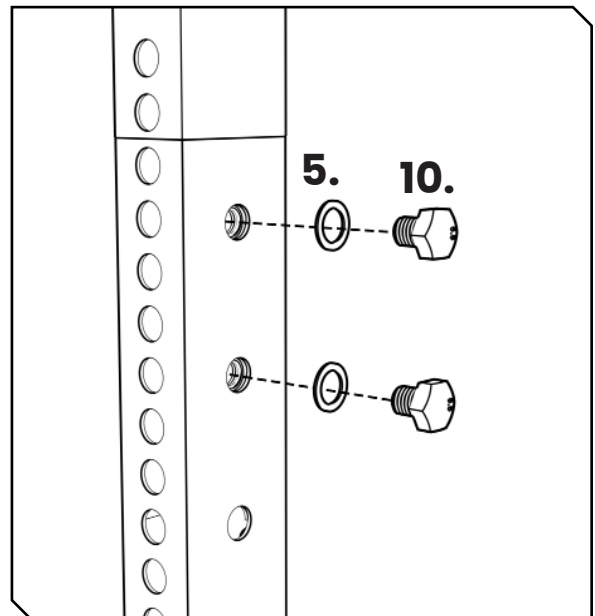

# ASSEMBLY

## STEP: 2A

# 16"

### STEP PART GUIDE

#	PART NAME	QTY
13.	2300-02	4
6.	M16 Washer	12
8.	M16x110mm Hex Screw	6
11.	M16 Nut	6

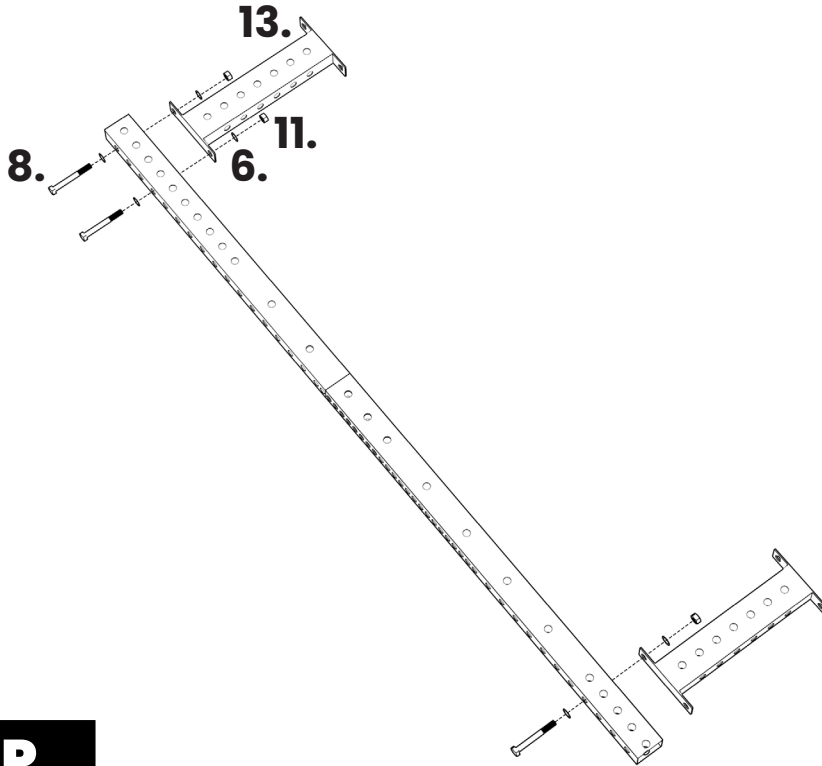

# x2

### TOP

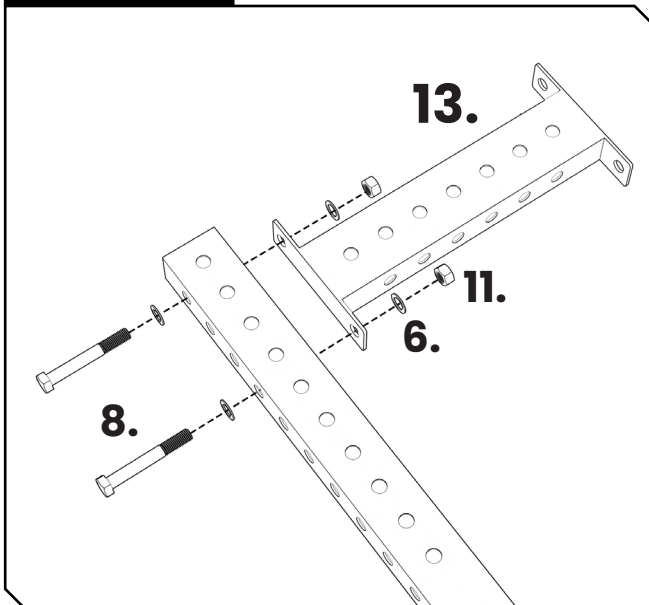

### BOTTOM

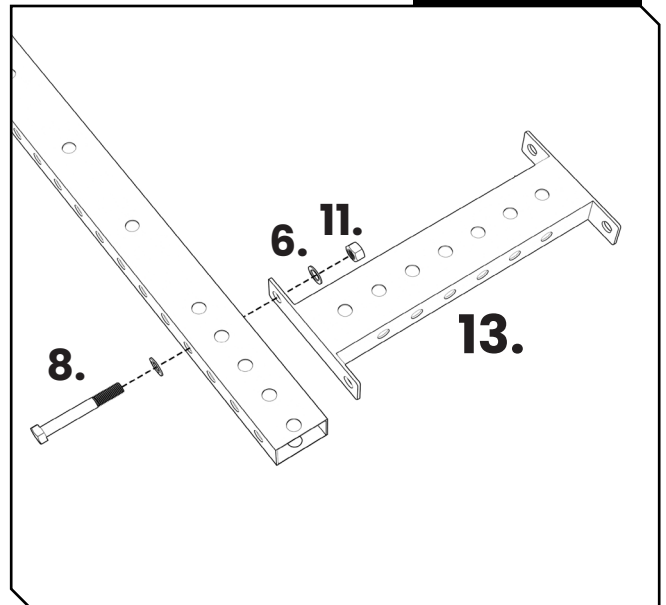

# ASSEMBLY

## STEP: 2B

# 24"

### STEP PART GUIDE

#	PART NAME	QTY
14.	2300-03	4
6.	M16 Washer	12
8.	M16x110mm Hex Screw	6
11.	M16 Nut	6

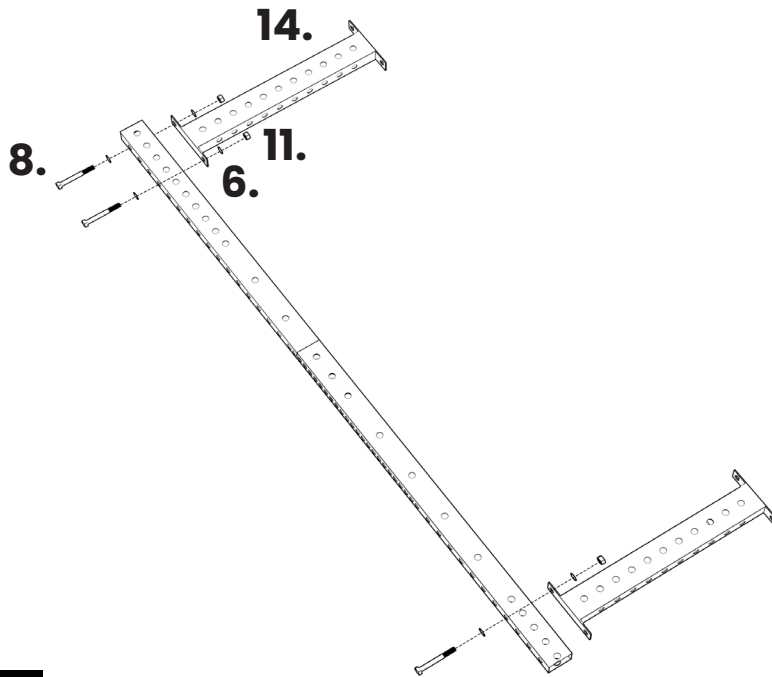

**TOP**

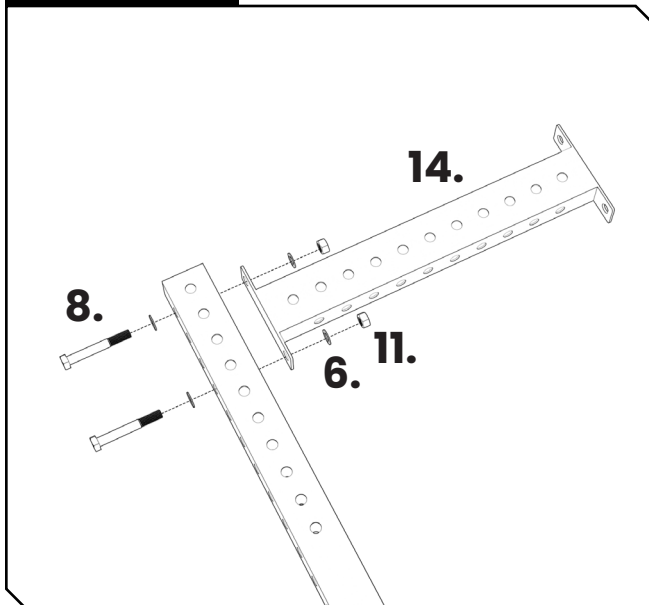

**BOTTOM**

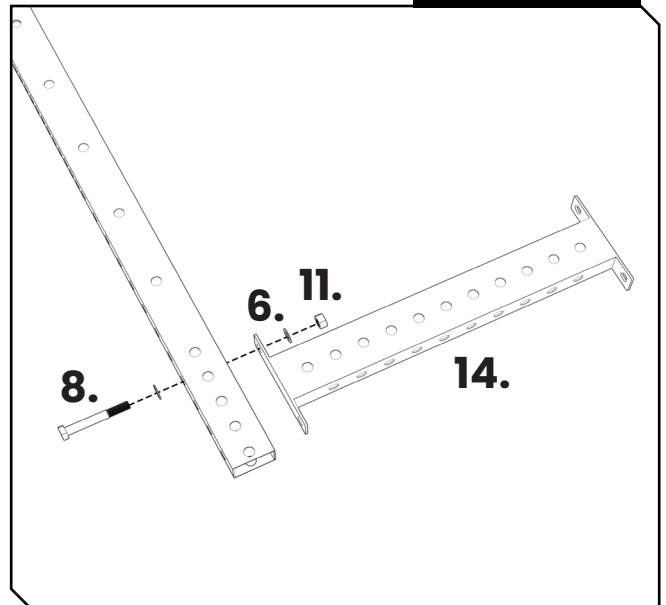

# ASSEMBLY

## STEP: 2C

# 36"

## STEP PART GUIDE

#	PART NAME	QTY
15.	2300-04	4
6.	M16 Washer	12
8.	M16x110mm Hex Screw	6
11.	M16 Nut	6

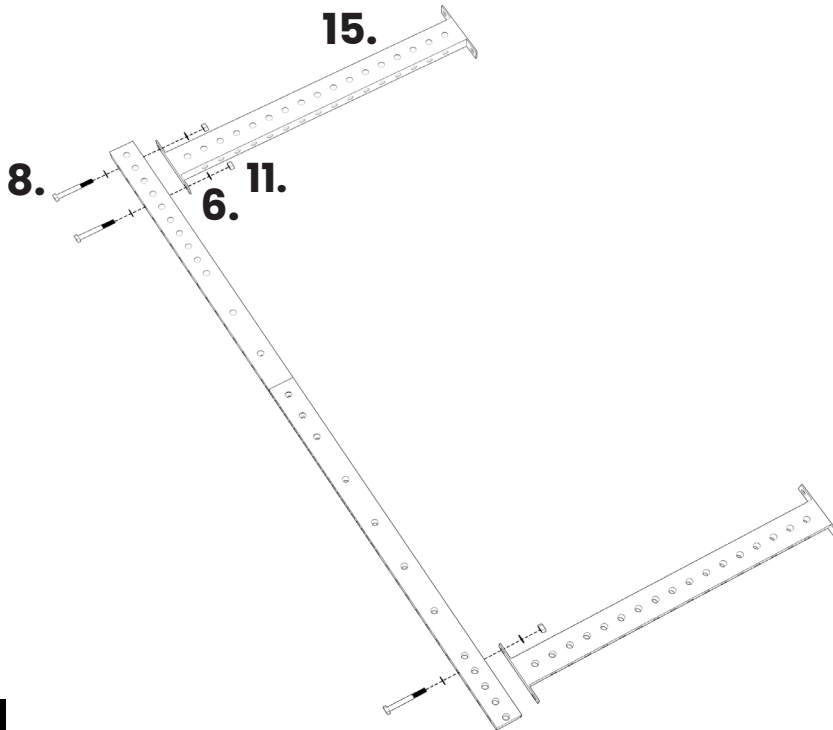

# x2

### TOP

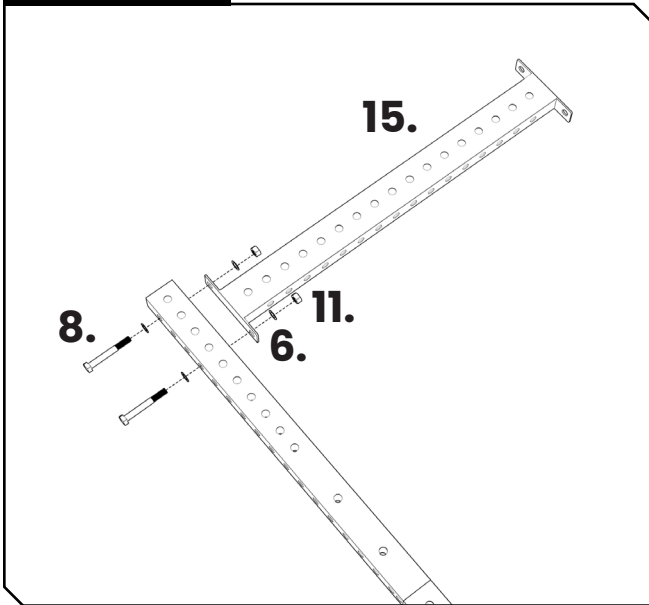

### BOTTOM

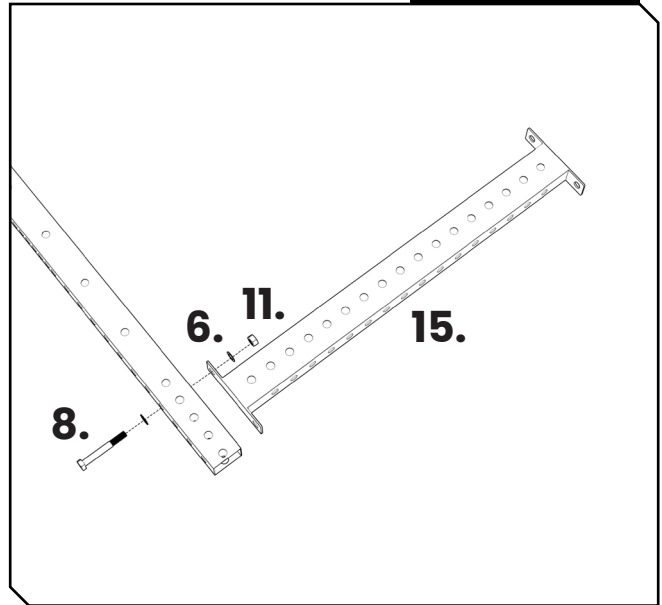

# ASSEMBLY

## STEP: 3

# STEP PART GUIDE

#	PART NAME	QTY
3.	2300-01-3	2
5.	M14 Washer	4
10.	M14x30mm Hex Screw	4

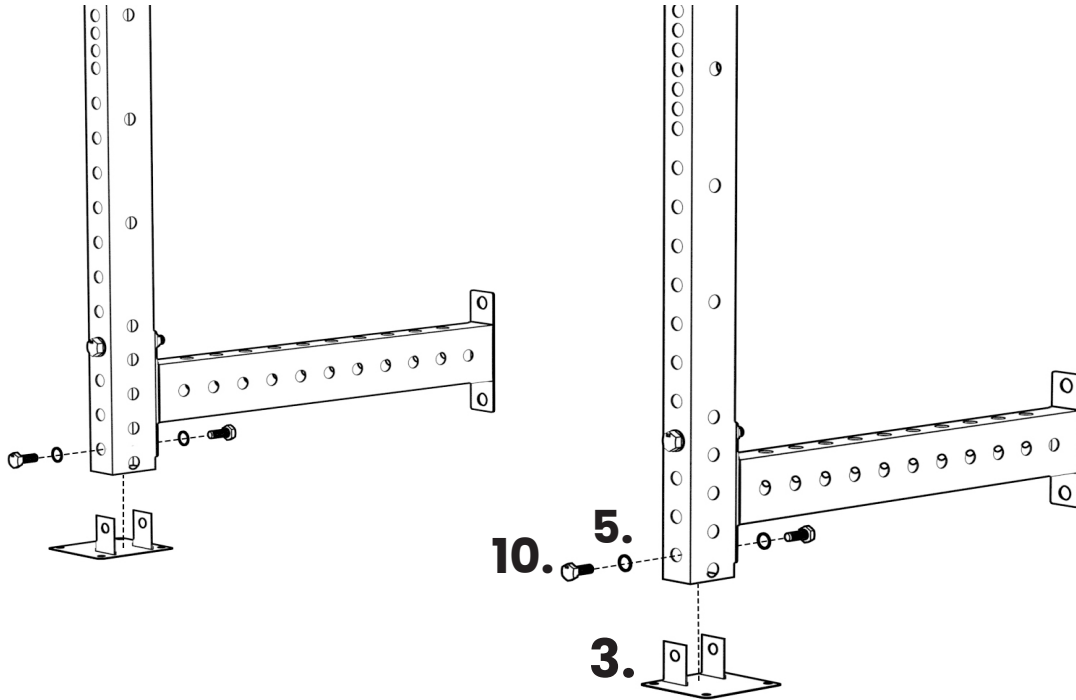

### STEP 3A

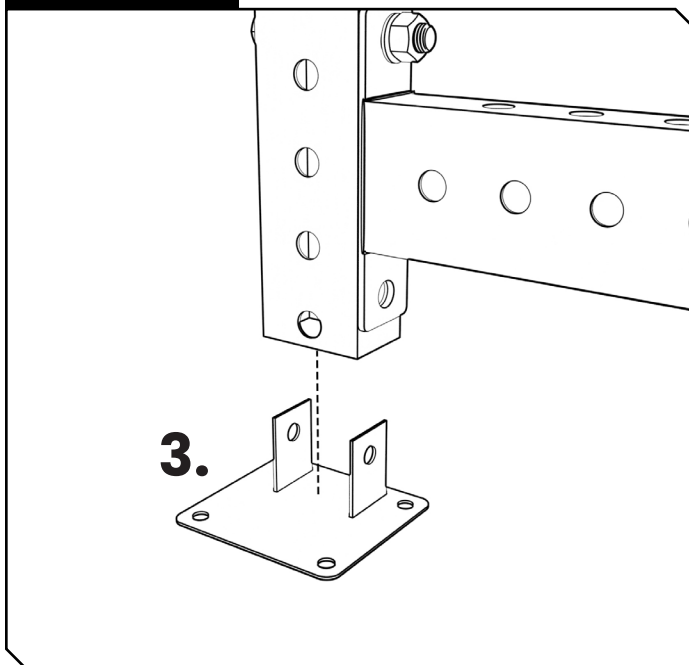

### STEP 3B

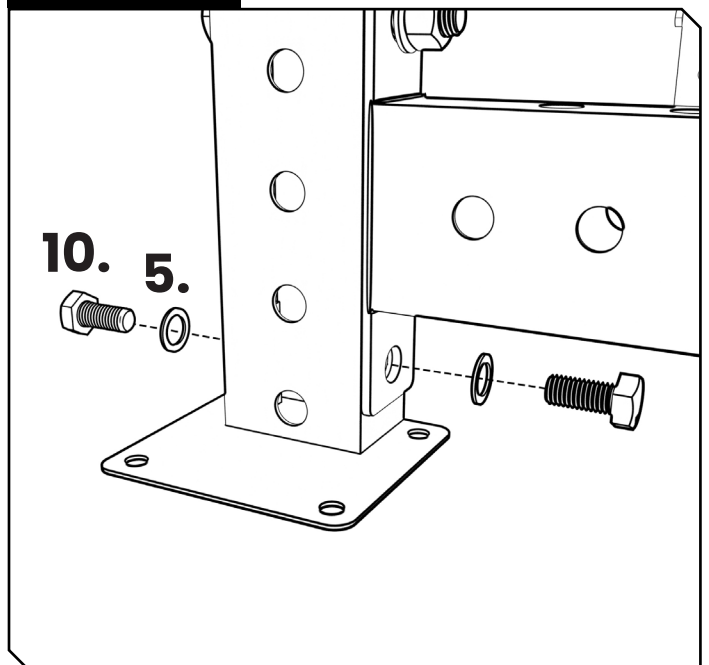



# ASSEMBLY

## STEP: 4A

# 16"



**SECURE FEET POINTING  
OUTWARDS**



## STEP PART GUIDE

#	PART NAME	QTY
4.	2300-05	1
6.	M16 Washer	8
8.	M16x80mm Hex Screw	4
11.	M16 Nut	4

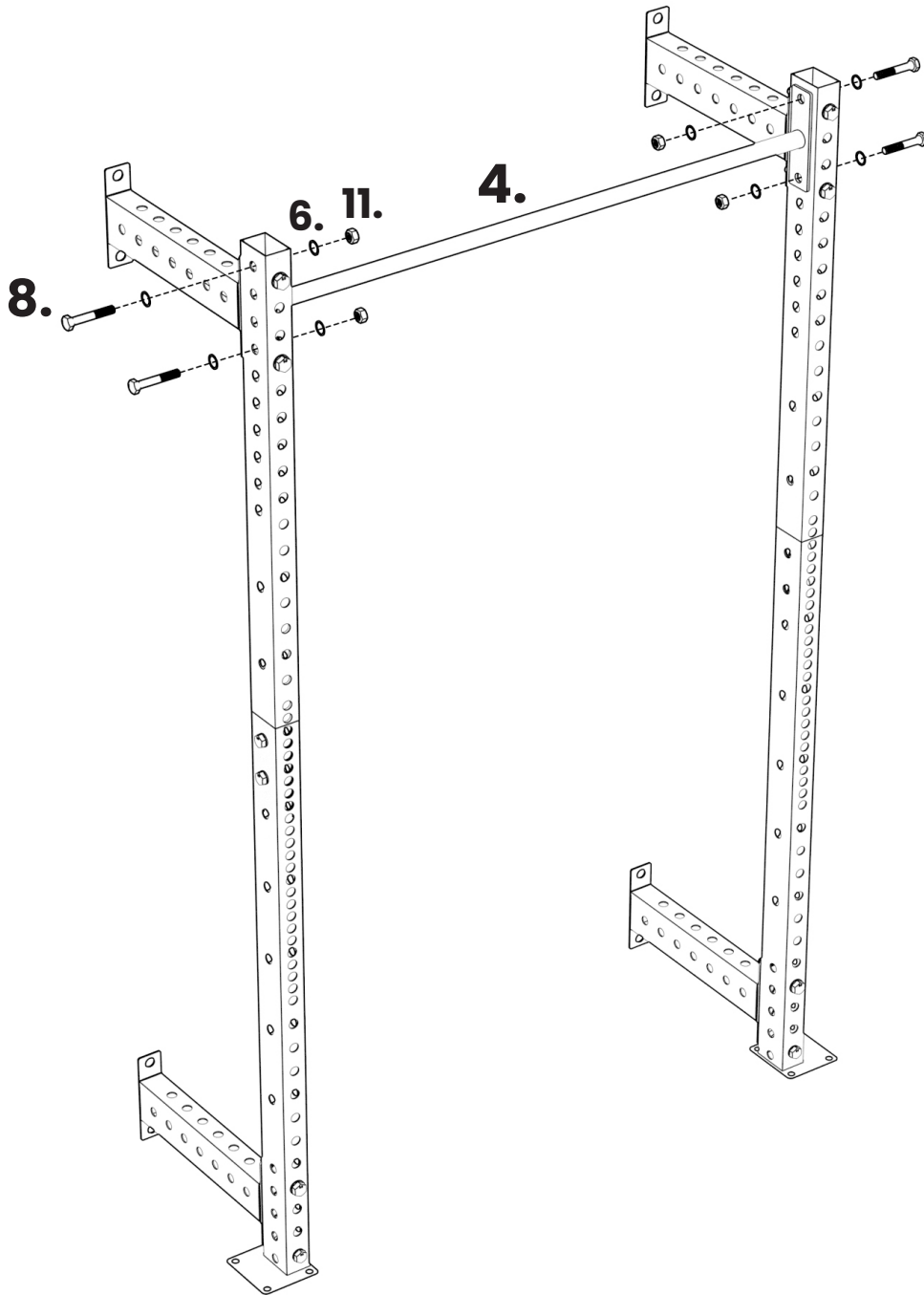

# ASSEMBLY

## STEP: 4B

# 24"



**SECURE FEET POINTING  
OUTWARDS**



## STEP PART GUIDE

#	PART NAME	QTY
4.	2300-05	1
6.	M16 Washer	8
8.	M16x80mm Hex Screw	4
11.	M16 Nut	4

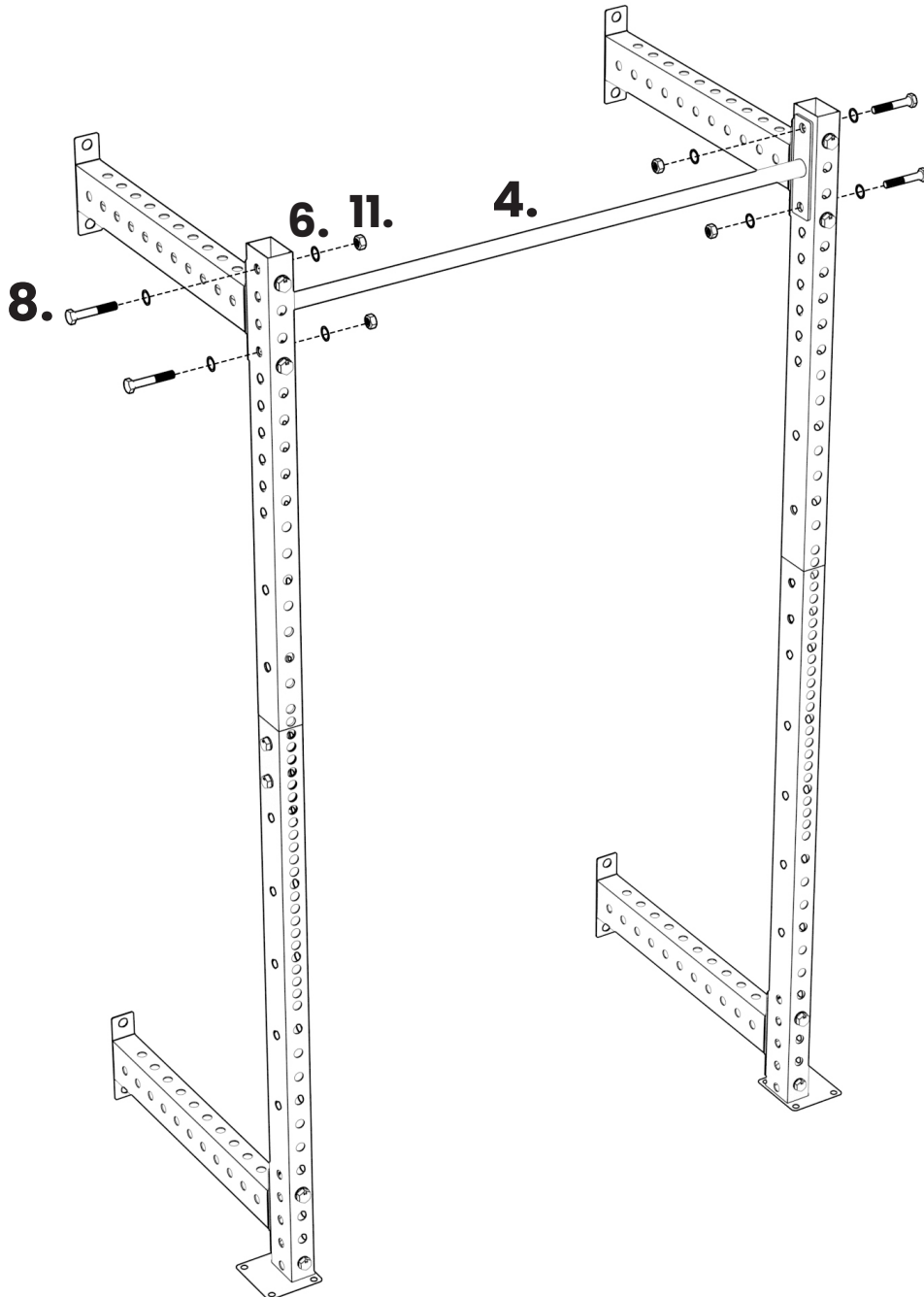

# ASSEMBLY

## STEP: 4C

# 36"



**SECURE FEET POINTING  
OUTWARDS**



## STEP PART GUIDE

#	PART NAME	QTY
4.	2300-05	1
6.	M16 Washer	8
8.	M16x80mm Hex Screw	4
11.	M16 Nut	4

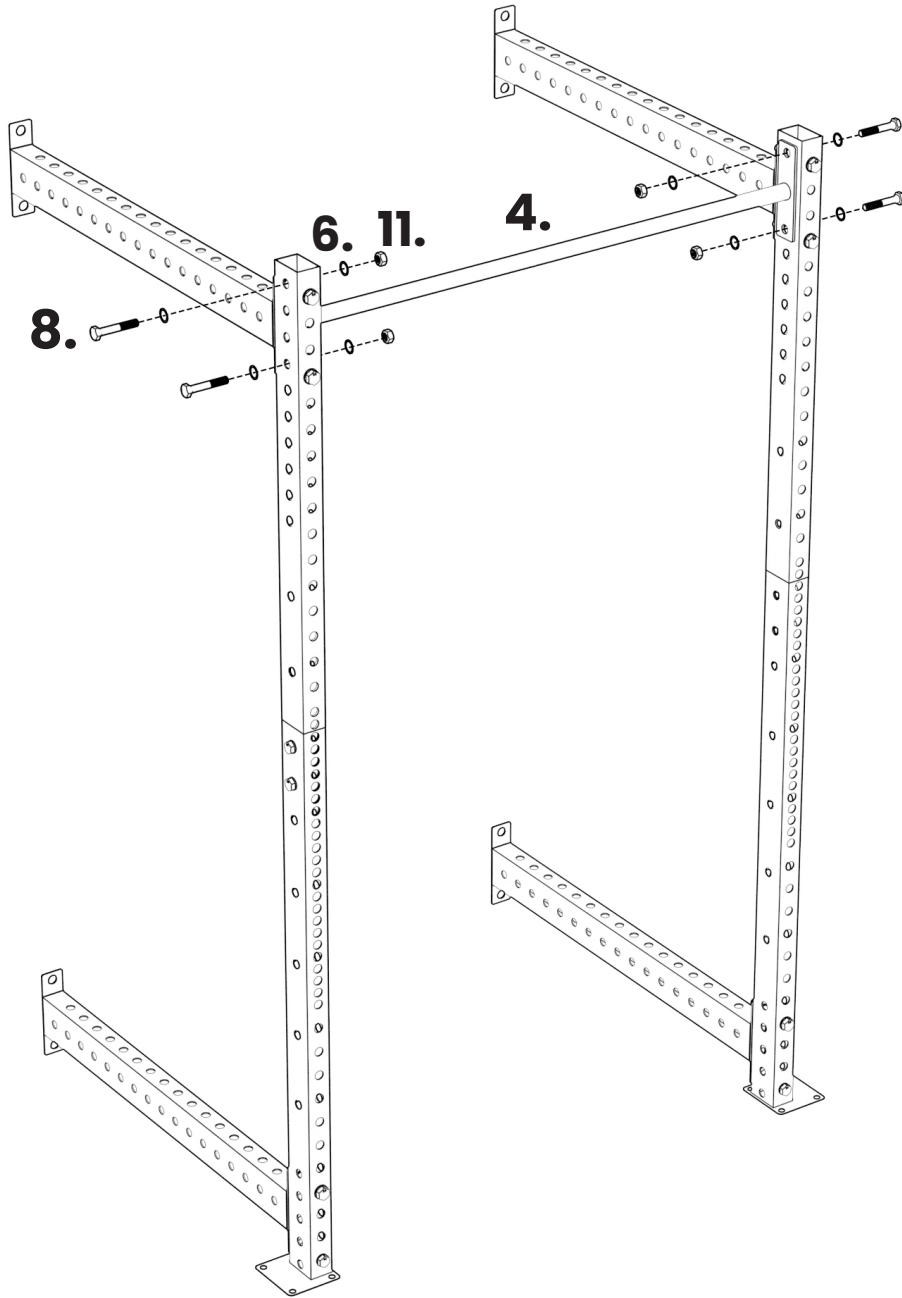

# ASSEMBLY

## STEP: 5

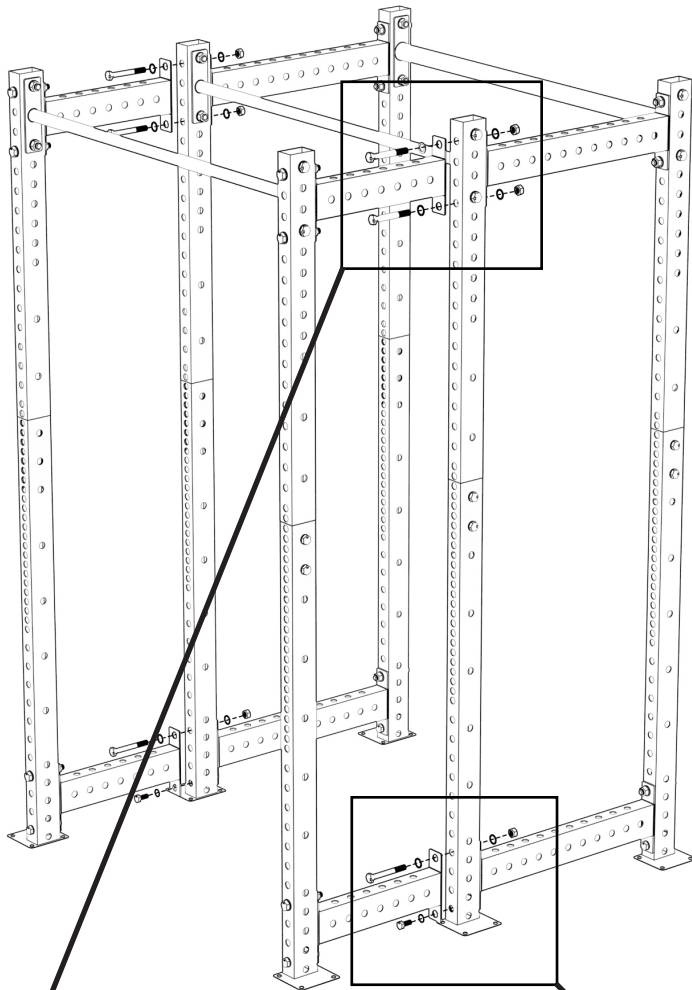

### **NOTICE**

**SCREWS PROVIDED  
BY POWER RACK  
ARE USED TO ATTACH  
EXTENSION**

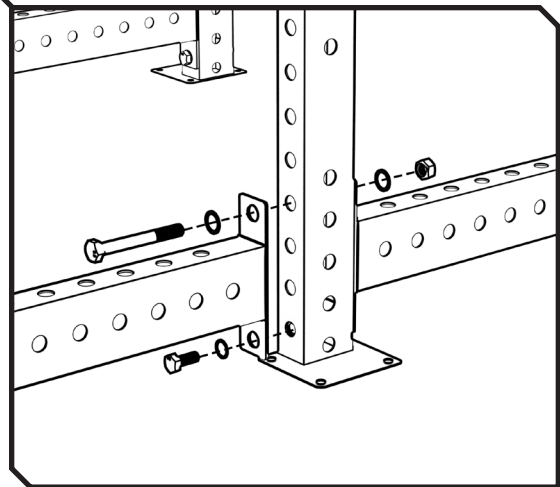
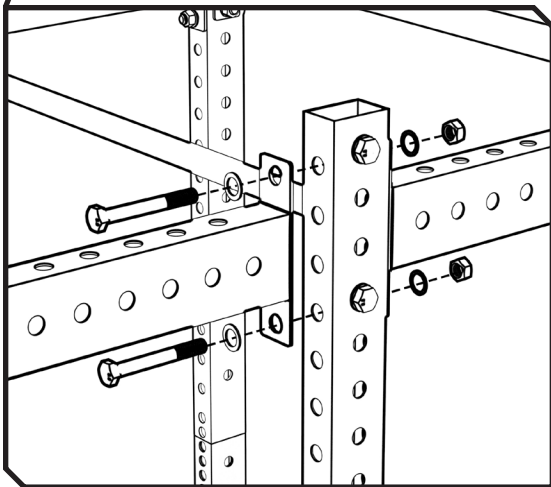

# ASSEMBLY

## STEP: 6

# STEP PART GUIDE

#	PART NAME	QTY
12.	M6 Expansion Screw	8

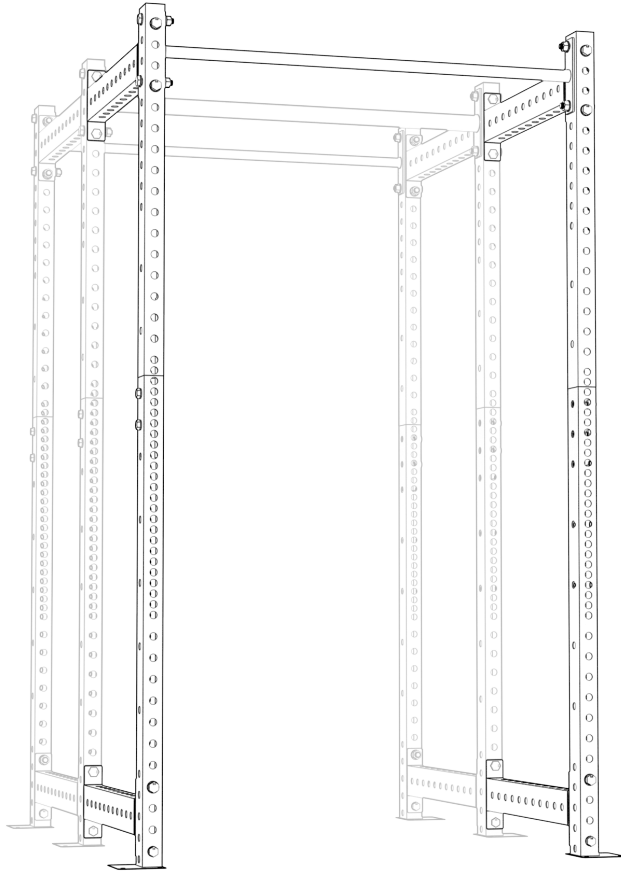

## ! IMPORTANT

**ENSURE RACK IS LEVEL TO THE FLOOR BY MEASURING TOP AND BOTTOM SPACING IS EQUAL.**

