

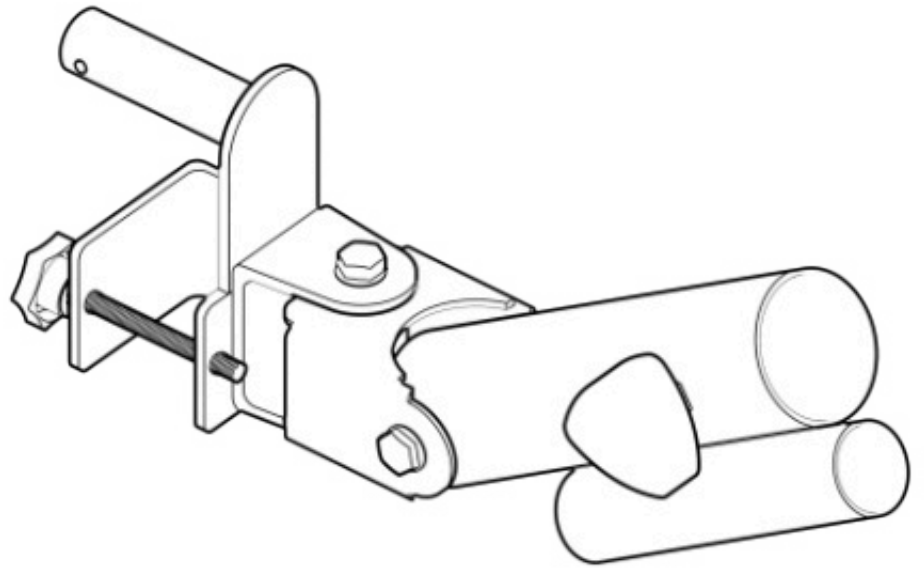





 **SYNERGEE[®]**



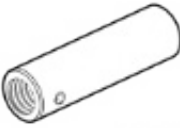

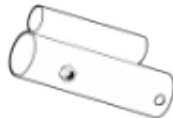

LANDMINE ATTACHMENT



PARTS LIST

IF ANY PIECES ARE MISSING, PLEASE CONTACT US IMMEDIATELY:
HELLO@SYNERGEEFITNESS.COM OR 1.855.217.7136

<p>1. QTY x1</p>  <p>CONVERTER SLEEVE</p>	<p>2. QTY x1</p>  <p>LANDMINE ATTACHMENT</p>	<p>3. QTY x1</p>  <p>LANDMINE</p>	<p>4. QTY x1</p>  <p>LANDMINE HINGE</p>	<p>5. QTY x1</p>  <p>SAFETY KNOB</p>
<p>6. QTY x1</p>  <p>BAR FASTENER</p>				

<p>A. QTY x1</p>  <p>M10X85 BOLT</p>	<p>B. QTY x1</p>  <p>M10X80 BOLT</p>	<p>C. QTY x2</p>  <p>M10 NUT</p>	<p>D. QTY x4</p>  <p>M10 WASHER</p>	<p>E. QTY x2</p>  <p>SPACER</p>
<p>F. QTY x1</p>  <p>#3 ALLEN KEY</p>	<p>G. QTY x2</p>  <p>#17 WRENCH</p>			

ASSEMBLY

STEP: 1

STEP PART GUIDE

#	PART NAME	QTY
2.	LANDMINE ATTACHMENT	1
4.	LANDMINE HINGE	1
B.	M10X80 BOLT	1
C.	M10 NUT	1
D.	M10 WASHER	2

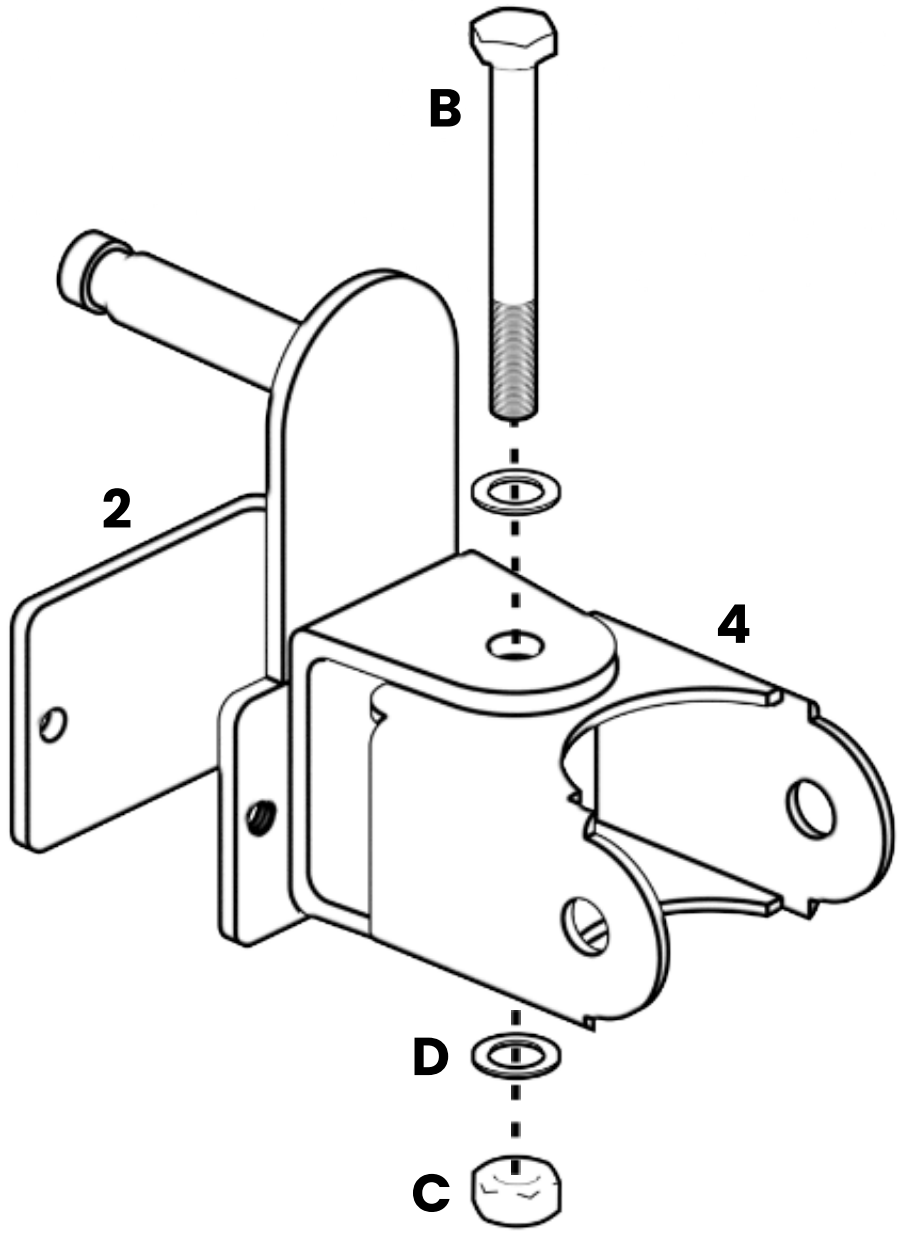

ASSEMBLY

STEP: 2

STEP PART GUIDE

#	PART NAME	QTY
3.	LANDMINE	1
A.	M10X85 BOLT	1
C.	M10 NUT	1
D.	M10 WASHER	2
E.	SPACER	2

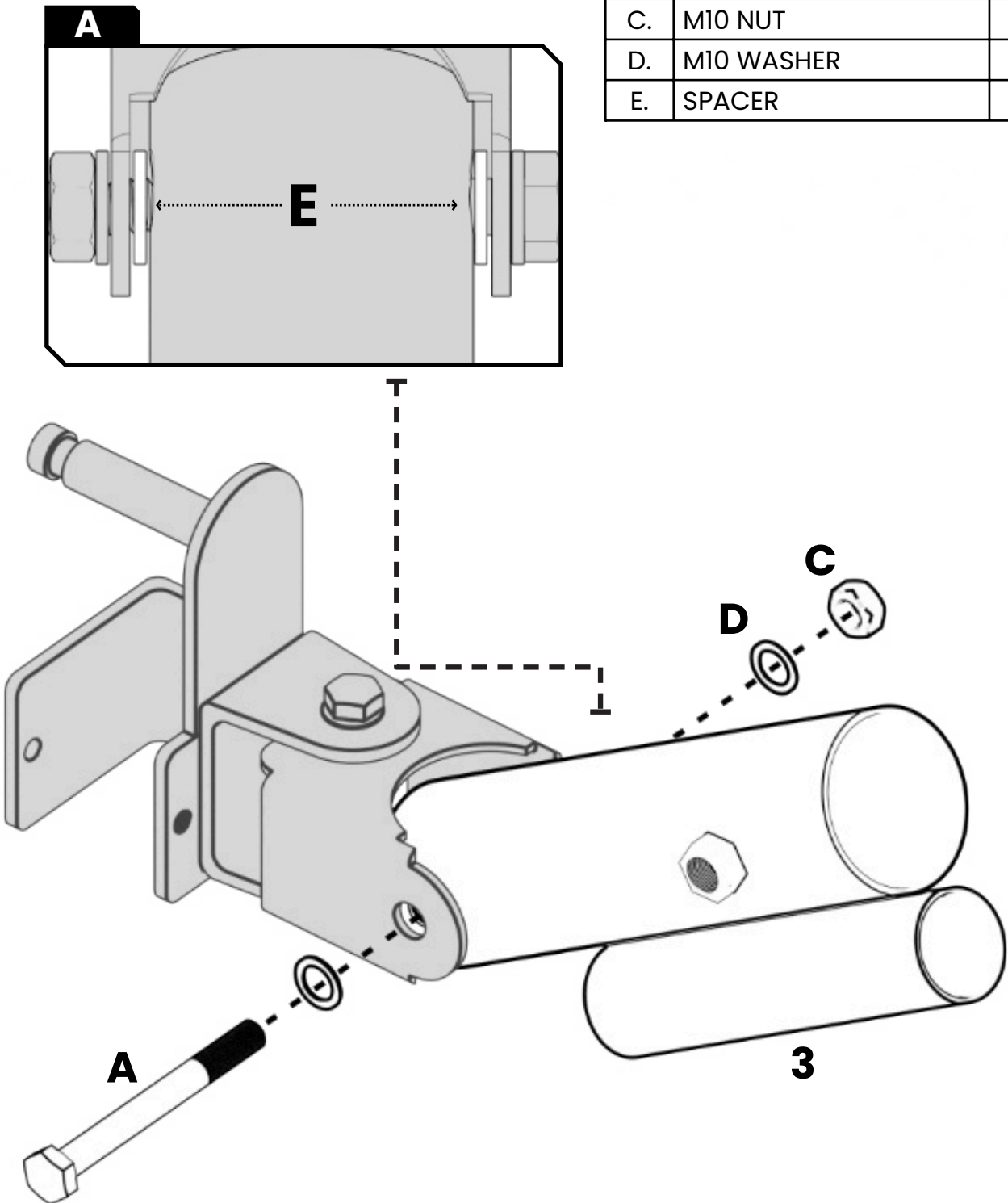

ASSEMBLY
STEP: 3

STEP PART GUIDE		
#	PART NAME	QTY
6.	BAR FASTENER	1

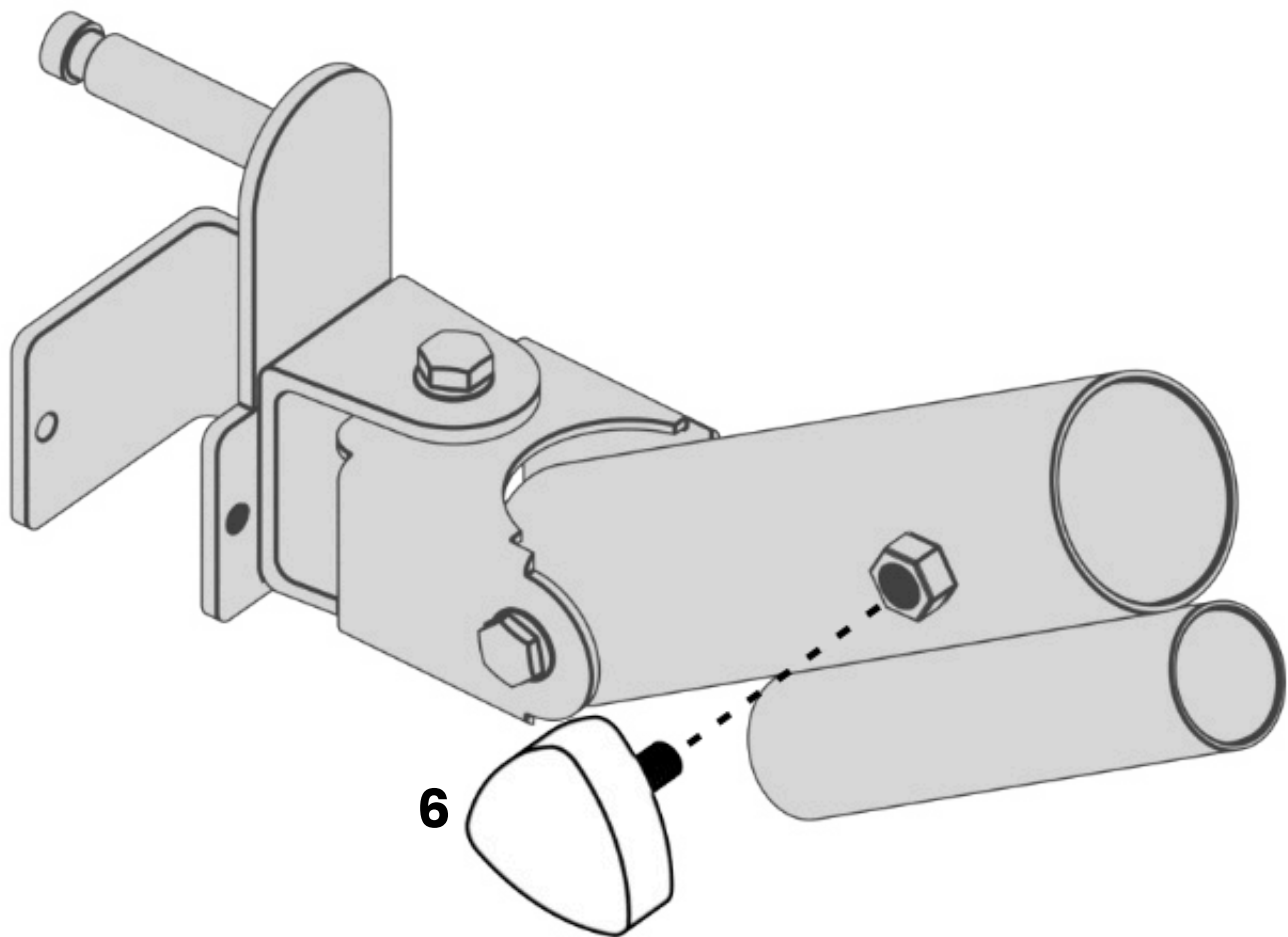

ASSEMBLY
STEP: 4

STEP PART GUIDE

#	PART NAME	QTY
1.	CONVERTER SLEEVE	1

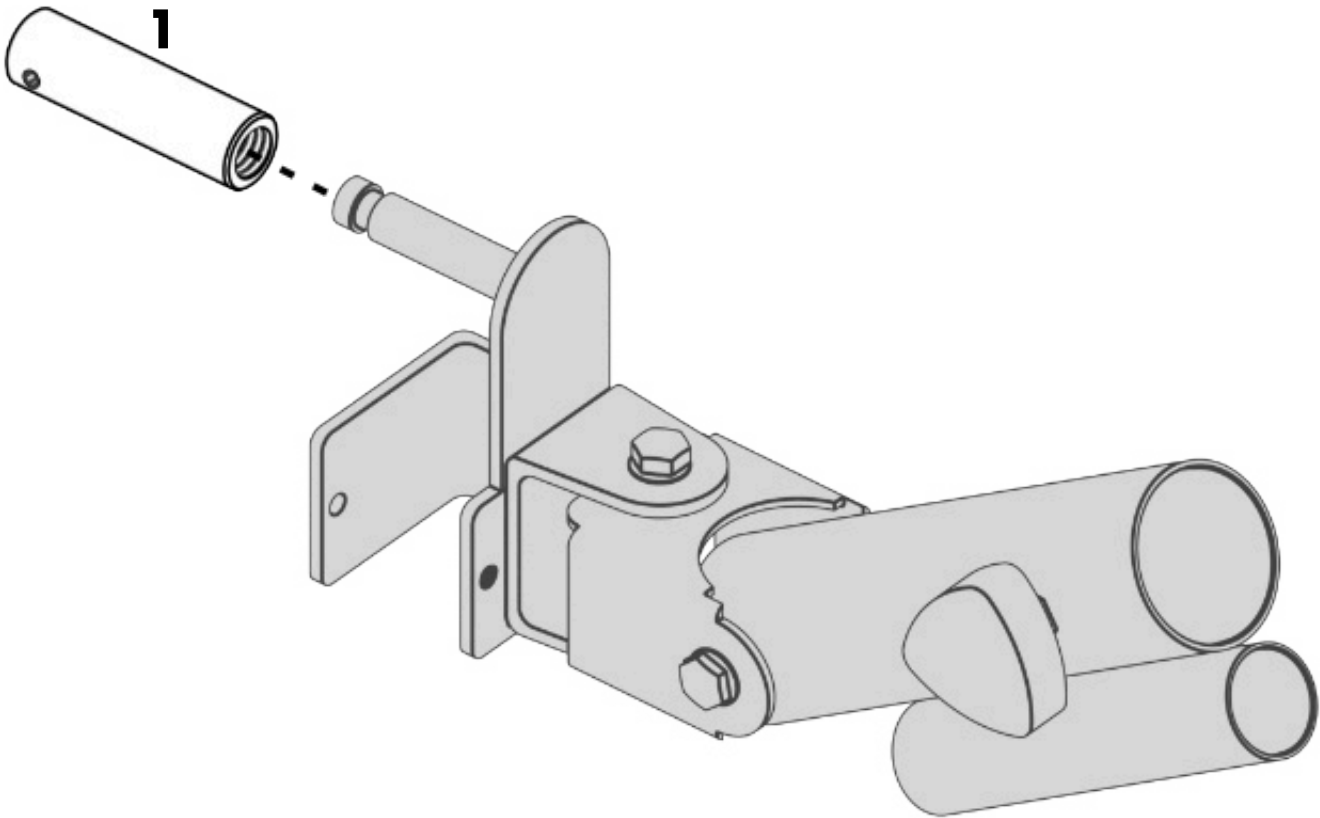

ASSEMBLY
STEP: 5

STEP PART GUIDE		
#	PART NAME	QTY
F.	#3 ALLEN KEY	1

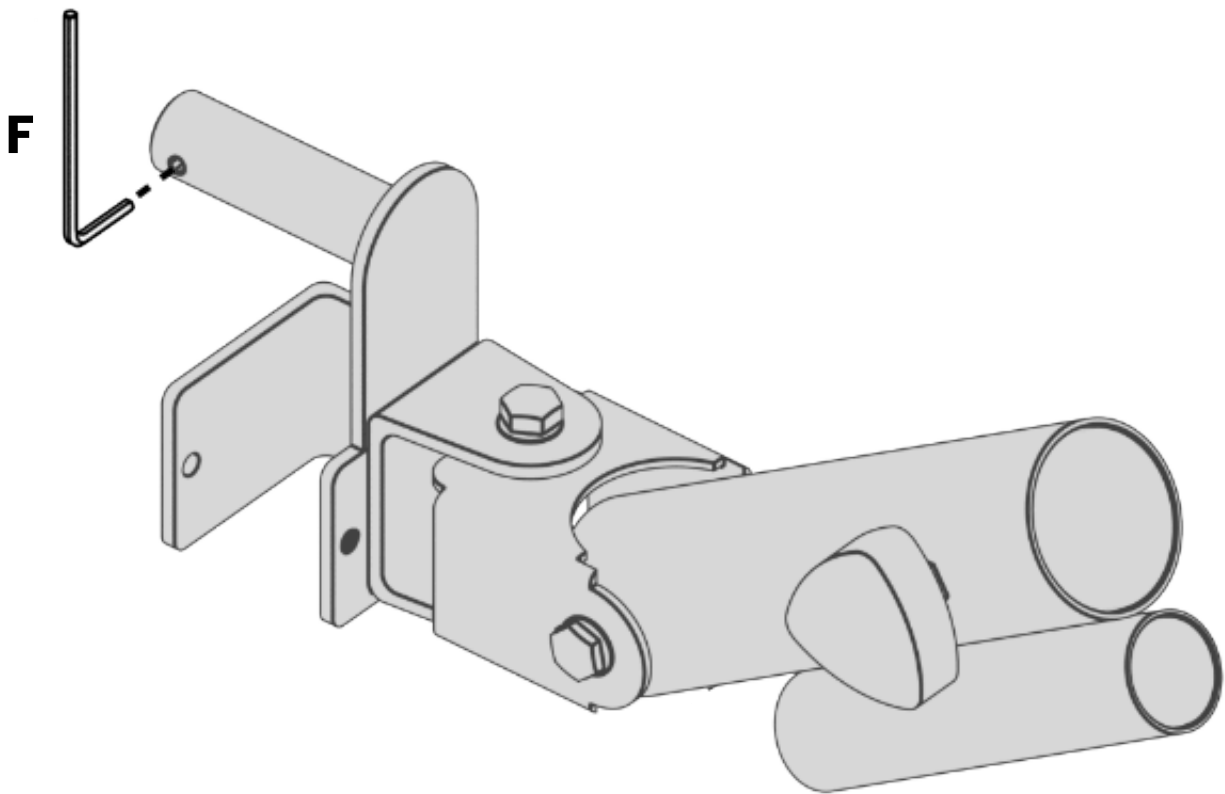

 **ATTENTION**
USE THE #3 ALLEN KEY
AND FASTEN UNTIL TIGHT

ASSEMBLY
STEP: 6

STEP PART GUIDE

#	PART NAME	QTY
5.	SAFETY KNOB	1

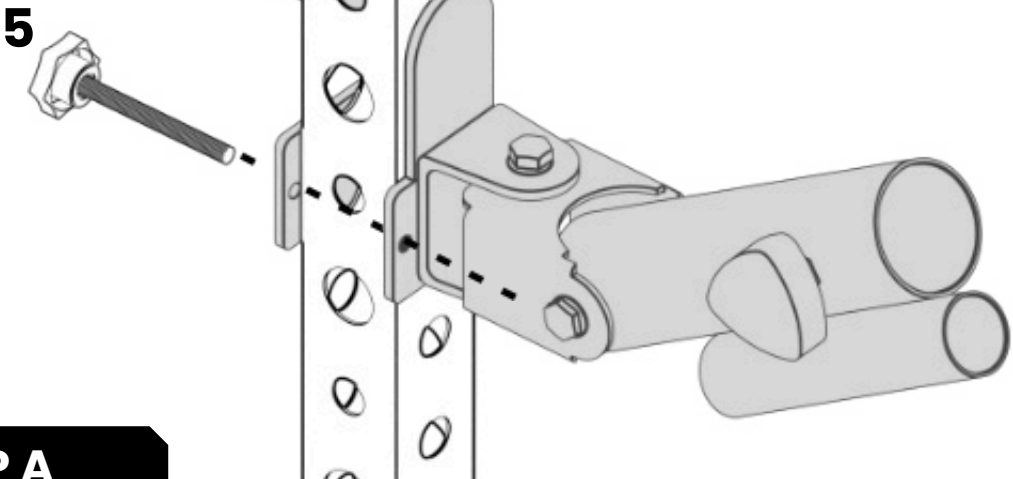

STEP A

STEP B

